

Instruction Manual  
for Portable Compressors  
English

XRXS 567 Cd - XRXS 1240 CD7  
XRXS 607 Cd - XRXS 1275 CD7  
XRVS 617 Cd - XRVS 1300 CD7  
XRVS 647 Cd - XRVS 1350 CD7

Engine CAT C18



**Instruction Manual  
for Portable Compressors**

**XRXS 567 Cd - XRXS 1240 CD7**

**XRXS 607 Cd - XRXS 1275 CD7**

**XRVS 617 Cd - XRVS 1300 CD7**

**XRVS 647 Cd - XRVS 1350 CD7**

Printed matter N°

9829 3007 48

07/2014

The Atlas Copco logo consists of the brand name "Atlas Copco" in a stylized, italicized serif font. It is positioned between two thick, solid black horizontal bars, one above and one below the text.

*Atlas Copco*

---

ATLAS COPCO - PORTABLE AIR DIVISION

[www.atlascopco.com](http://www.atlascopco.com)

---

### **Warranty and Liability Limitation**

Use only authorized parts.

Any damage or malfunction caused by the use of unauthorized parts is not covered by Warranty or Product Liability.

The manufacturer does not accept any liability for any damage arising for modifications, additions or conversions made without the manufacturer's approval in writing.

While every effort has been made to ensure that the information in this manual is correct, Atlas Copco does not assume responsibility for possible errors.

Copyright 2014, Atlas Copco Airpower n.v., Antwerp, Belgium.

Any unauthorized use or copying of the contents or any part thereof is prohibited.

This applies in particular to trademarks, model denominations, part numbers and drawings.

## Preface

Please read the following instructions carefully before starting to use your compressor.

It is a solid, safe and reliable machine, built according to the latest technology. Follow the instructions in this booklet and we guarantee you years of troublefree operation.

Always keep the manual available near the machine.

In all correspondence always mention the compressor type and serial number, shown on the data plate.

The company reserves the right to make changes without prior notice.

## Table of contents

|          |  |    |
|----------|--|----|
| <b>1</b> | <b>Safety precautions</b> .....                          | 7  |
| 1.1      | Introduction .....                                       | 7  |
| 1.2      | General safety precautions .....                         | 8  |
| 1.3      | Safety during transport and installation .....           | 9  |
| 1.4      | Safety during use and operation .....                    | 9  |
| 1.5      | Safety during maintenance and repair .....               | 11 |
| 1.6      | Tool applications safety .....                           | 12 |
| 1.7      | Specific safety precautions .....                        | 13 |
| <b>2</b> | <b>Leading particulars</b> .....                         | 14 |
| 2.1      | General description .....                                | 14 |
| <b>3</b> | <b>Main parts</b> .....                                  | 16 |
| 3.1      | Regulating system .....                                  | 18 |
| 3.1.1    | Overview .....   | 18 |
| 3.1.2    | Air flow .....   | 19 |
| 3.1.3    | Oil system .....   | 19 |
| 3.1.4    | Pneumatic regulating system .....                        | 20 |
| 3.2      | Electric system .....                                    | 22 |
| 3.3      | Markings and information labels .....                    | 24 |
| <b>4</b> | <b>Operating instructions</b> .....                      | 25 |
| 4.1      | Parking, towing and lifting instructions .....           | 25 |
| 4.1.1    | Parking instructions Wagon .....                         | 25 |
| 4.1.2    | Towing instructions Wagon .....                          | 26 |
| 4.1.3    | Towbar levelling Wagon .....                             | 26 |
| 4.1.4    | Lifting instructions .....                               | 26 |
| 4.2      | Internal lighting .....                                  | 27 |
| 4.3      | Preheater (option) .....                                 | 27 |
| 4.3.1    | Description heating operation .....                      | 27 |
| 4.4      | Before starting .....                                    | 29 |
| <b>5</b> | <b>Starting / Stopping</b> .....                         | 30 |
| 5.1      | BATTERY SWITCH .....                                     | 30 |
| 5.1.1    | Control panel .....                                      | 30 |
| 5.1.2    | Operations overview .....                                | 33 |
| 5.1.3    | Battery switch .....                                     | 33 |
| 5.1.4    | Overview icons .....                                     | 34 |
| 5.1.5    | Possible views .....                                     | 36 |
| 5.1.6    | Starting .....   | 37 |
| 5.1.7    | Stopping .....   | 43 |
| 5.1.8    | Shutdown .....   | 44 |
| 5.1.9    | Power off .....  | 44 |
| 5.1.10   | DIESEL PARTICULATE FILTER<br>REGENERATION 44             |    |
| 5.1.11   | Automatic DPF Regeneration (Default)                     | 45 |
| 5.1.12   | Inhibit DPF Regeneration .....                           | 46 |
| 5.1.13   | Increasing Soot Load .....                               | 46 |
| 5.1.14   | Force DPF Regeneration .....                             | 48 |
| 5.1.15   | Settings .....   | 49 |
| 5.1.16   | Fault codes .....  | 51 |
| 5.1.17   | Emergency stop .....                                     | 54 |
| <b>6</b> | <b>Maintenance</b> .....                                 | 55 |
| 6.1      | Liability .....  | 55 |
| 6.2      | Service paks .....                                       | 55 |
| 6.3      | Service kits .....                                       | 55 |
| 6.3.1    | Storage .....  | 55 |
| 6.3.2    | Safety precautions .....                                 | 55 |
| 6.4      | Preventive maintenance schedule for the<br>compressor 56 |    |
| 6.5      | Oil specifications .....                                 | 59 |
| 6.5.1    | Compressor oil .....                                     | 59 |
| 6.5.2    | Engine oil .....   | 60 |
| 6.6      | Oil level check .....                                    | 61 |
| 6.6.1    | Check engine oil level .....                             | 61 |

### **CALIFORNIA Proposition 65 Warning**

Diesel engine exhaust and some of its constituents are known to the State of California to cause cancer, birth defects, and other reproductive harm.

|          |  |           |           |  |    |           |                              |    |
|----------|--|-----------|-----------|--|----|-----------|------------------------------|----|
| 6.6.2    | Check compressor oil level .....   | 61        | 7.2.1     | Priming instructions .....   | 72 | <b>13</b> | <b>Disposal</b> .....        | 98 |
| 6.7      | Oil and oil filter change .....  | 62        | 7.2.2     | Replacing filter elements .....  | 73 | 13.1      | General .....                | 98 |
| 6.7.1    | Engine oil and oil filter change .....                                   | 62        | 7.2.3     | Cleaning crankcase breather filter .....   | 73 | 13.2      | Disposal of materials .....  | 98 |
| 6.7.2    | Topping up the compressor oil .....                                      | 62        | 7.2.4     | Maintenance Quick action fuel couplings...<br>74                                   |    | <b>14</b> | <b>Maintenance Log</b> ..... | 99 |
| 6.7.3    | Compressor oil and oil filter change .....                               | 62        | 7.3       | Brake adjustments .....  | 74 |           |                              |    |
| 6.8      | Coolant specifications .....   | 63        | 7.3.1     | Brake shoe adjustment Wagon .....  | 74 |           |                              |    |
| 6.8.1    | PARCOOL EG .....   | 64        | 7.3.2     | Brake adjustment wagon .....   | 75 |           |                              |    |
| 6.8.2    | Handling PARCOOL EG .....  | 65        | <b>8</b>  | <b>Problem solving</b> .....   | 76 |           |                              |    |
| 6.9      | Coolant check .....  | 65        | 8.1       | Heater failure .....   | 79 |           |                              |    |
| 6.10     | Topping up/replacing coolant .....                                       | 65        | 8.2       | Oiltronix failure .....  | 79 |           |                              |    |
| 6.10.1   | Topping up without draining from the<br>cooling system 66                |           | <b>9</b>  | <b>Available options</b> .....   | 80 |           |                              |    |
| 6.10.2   | Topping up after limited quantity draining<br>from the cooling system 67 |           | <b>10</b> | <b>Technical specifications</b> .....  | 87 |           |                              |    |
| 6.10.3   | Replacing the coolant .....  | 68        | 10.1      | Torque values .....  | 87 |           |                              |    |
| 6.11     | Cleaning coolers .....   | 68        | 10.1.1    | General torque values .....  | 87 |           |                              |    |
| 6.12     | Battery care .....   | 69        | 10.1.2    | Critical torque values .....   | 87 |           |                              |    |
| 6.12.1   | Electrolyte .....  | 69        | 10.2      | Compressor / engine specifications .....   | 88 |           |                              |    |
| 6.12.2   | Activating a dry-charged battery .....                                   | 69        | 10.2.1    | Reference conditions .....   | 88 |           |                              |    |
| 6.12.3   | Recharging a battery .....   | 69        | 10.2.2    | Limitations .....  | 88 |           |                              |    |
| 6.12.4   | Battery maintenance .....  | 69        | 10.2.3    | Performance data .....   | 89 |           |                              |    |
| 6.13     | Compressor element overhaul .....  | 69        | 10.2.4    | Altitude unit performance curve .....  | 91 |           |                              |    |
| <b>7</b> | <b>Adjustments and servicing procedures</b> ..                           | <b>70</b> | 10.2.5    | Design data .....  | 92 |           |                              |    |
| 7.0.1    | Adjustment of the pneumatic regulating<br>system 70                      |           | <b>11</b> | <b>Dataplate</b> .....   | 95 |           |                              |    |
| 7.1      | Air filters engine / compressor .....                                    | 71        | <b>12</b> | <b>Legislation</b> .....   | 96 |           |                              |    |
| 7.1.1    | Main parts .....   | 71        | 12.1      | Parts, subjected to Pressure Equipment<br>Directive 97/23/EC, cat. II and above 96 |    |           |                              |    |
| 7.1.2    | Cleaning the dust trap .....   | 71        | 12.2      | Parts, subjected to cat. I and covered by the<br>Machine Directive 89/392/EC 97    |    |           |                              |    |
| 7.1.3    | Replacing the filter element and the safety<br>cartridge 71              |           | 12.3      | Parts, subjected to art. I, paragraph 3.3 .....                                    | 97 |           |                              |    |
| 7.1.4    | Air receiver .....   | 72        |           |  |    |           |                              |    |
| 7.1.5    | Safety valve .....   | 72        |           |  |    |           |                              |    |
| 7.2      | Fuel system .....  | 72        |           |  |    |           |                              |    |

# Safety precautions



To be read attentively and acted accordingly before towing, lifting, operating, performing maintenance or repairing the compressor.

## INTRODUCTION

The policy of Atlas Copco is to provide the users of their equipment with safe, reliable and efficient products. Factors taken into account are among others:

- the intended and predictable future use of the products, and the environments in which they are expected to operate,
- applicable rules, codes and regulations,
- the expected useful product life, assuming proper service and maintenance,
- providing the manual with up-to-date information.

Before handling any product, take time to read the relevant instruction manual. Besides giving detailed operating instructions, it also gives specific information about safety, preventive maintenance, etc.

Keep the manual always at the unit location, easy accessible to the operating personnel.

See also the safety precautions of the engine and possible other equipment, which are separately sent along or are mentioned on the equipment or parts of the unit.

These safety precautions are general and some statements will therefore not always apply to a particular unit.

Only people that have the right skills should be allowed to operate, adjust, perform maintenance or repair on Atlas Copco equipment.

It is the responsibility of management to appoint operators with the appropriate training and skill for each category of job.

### **Skill level 1: Operator**

An operator is trained in all aspects of operating the unit with the push-buttons, and is trained to know the safety aspects.

### **Skill level 2: Mechanical technician**

A mechanical technician is trained to operate the unit the same as the operator. In addition, the mechanical technician is also trained to perform maintenance and repair, as described in the instruction manual, and is allowed to change settings of the control and safety system. A mechanical technician does not work on live electrical components.

### **Skill level 3: Electrical technician**

An electrical technician is trained and has the same qualifications as both the operator and the mechanical technician. In addition, the electrical technician may carry out electrical repairs within the various enclosures of the unit. This includes work on live electrical components.

### **Skill level 4: Specialist from the manufacturer**

This is a skilled specialist sent by the manufacturer or its agent to perform complex repairs or modifications to the equipment.

In general it is recommended that not more than two people operate the unit, more operators could lead to unsafe operating conditions.

Take necessary steps to keep unauthorized persons away from the unit and eliminate all possible sources of danger at the unit.

When handling, operating, overhauling and/or performing maintenance or repair on Atlas Copco equipment, the mechanics are expected to use safe engineering practices and to observe all relevant local safety requirements and ordinances. The following list is a reminder of special safety directives and precautions mainly applicable to Atlas Copco equipment.

These safety precautions apply to machinery processing or consuming air. Processing of any other gas requires additional safety precautions typical to the application and are not included herein.

Neglecting the safety precautions may endanger people as well as environment and machinery:

- endanger people due to electrical, mechanical or chemical influences,
- endanger the environment due to leakage of oil, solvents or other substances,
- endanger the machinery due to function failures.

All responsibility for any damage or injury resulting from neglecting these precautions or by non-observance of ordinary caution and due care required in handling, operating, maintenance or repair, also if not expressly mentioned in this instruction manual, is disclaimed by Atlas Copco.

The manufacturer does not accept any liability for any damage arising from the use of non-original parts and for modifications, additions or conversions made without the manufacturer's approval in writing.

If any statement in this manual does not comply with local legislation, the stricter of the two shall be applied.

Statements in these safety precautions should not be interpreted as suggestions, recommendations or inducements that it should be used in violation of any applicable laws or regulations.

## GENERAL SAFETY PRECAUTIONS

- 1 The owner is responsible for maintaining the unit in a safe operating condition. Unit parts and accessories must be replaced if missing or unsuitable for safe operation.
- 2 The supervisor, or the responsible person, shall at all times make sure that all instructions regarding machinery and equipment operation and maintenance are strictly followed and that the machines with all accessories and safety devices, as well as the consuming devices, are in good repair, free of abnormal wear or abuse, and are not tampered with.
- 3 Whenever there is an indication or any suspicion that an internal part of a machine is overheated, the machine shall be stopped but no inspection covers shall be opened before sufficient cooling time has elapsed; this to avoid the risk of spontaneous ignition of oil vapour when air is admitted.
- 4 Normal ratings (pressures, temperatures, speeds, etc.) shall be durably marked.
- 5 Operate the unit only for the intended purpose and within its rated limits (pressure, temperature, speeds, etc.).
- 6 The machinery and equipment shall be kept clean, i.e. as free as possible from oil, dust or other deposits.
- 7 To prevent an increase in working temperature, inspect and clean heat transfer surfaces (cooler fins, intercoolers, water jackets, etc.) regularly. See the **Preventive maintenance schedule for the compressor**.
- 8 All regulating and safety devices shall be maintained with due care to ensure that they function properly. They may not be put out of action.
- 9 Care shall be taken to avoid damage to safety valves and other pressure-relief devices, especially to avoid plugging by paint, oil coke or dirt accumulation, which could interfere with the functioning of the device.
- 10 Pressure and temperature gauges shall be checked regularly with regard to their accuracy. They shall be replaced whenever outside acceptable tolerances.
- 11 Safety devices shall be tested as described in the maintenance schedule of the instruction manual to determine that they are in good operating condition. See the **Preventive maintenance schedule for the compressor**.
- 12 Mind the markings and information labels on the unit.
- 13 In the event the safety labels are damaged or destroyed, they must be replaced to ensure operator safety.
- 14 Keep the work area neat. Lack of order will increase the risk of accidents.
- 15 When working on the unit, wear safety clothing. Depending on the kind of activities these are: safety glasses, ear protection, safety helmet (including visor), safety gloves, protective clothing, safety shoes. Do not wear the hair long and loose (protect long hair with a hairnet), or wear loose clothing or jewelry.
- 16 Take precautions against fire. Handle fuel, oil and anti-freeze with care because they are inflammable substances. Do not smoke or approach with naked flame when handling such substances. Keep a fire-extinguisher in the vicinity.



## **SAFETY DURING TRANSPORT AND INSTALLATION**

Transport of the unit has to be done by authorized/experienced people.

When towing, lifting or transporting the compressor in any way, the battery switch must always be in the "OFF" position!

To lift a unit, all loose or pivoting parts, e.g. doors and tow bar, shall first be securely fastened.

Do not attach cables, chains or ropes directly to the lifting eye; apply a crane hook or lifting shackle meeting local safety regulations. Never allow sharp bends in lifting cables, chains or ropes.

Helicopter lifting is not allowed.

It is strictly forbidden to dwell or stay in the risk zone under a lifted load. Never lift the unit over people or residential areas. Lifting acceleration and retardation shall be kept within safe limits.

### **1 Before towing the unit:**

- ascertain that the pressure vessel(s) is (are) depressurized,
- check the tow bar, the brake system and the towing eye. Also check the coupling of the towing vehicle,
- check the towing and brake capability of the towing vehicle,
- check that the tow bar, jockey wheel or stand leg is safely locked in the raised position,
- ascertain that the towing eye can swivel freely on the hook,
- check that the wheels are secure and that the tyres are in good condition and inflated correctly,
- connect the signalisation cable, check all lights and connect the pneumatic brake couplers,

- attach the safety break-away cable or safety chain to the towing vehicle,
  - remove wheel chocks, if applied, and disengage the parking brake,
  - check whether springs on wheelchocks are missing or broken.
- 2 To tow a unit use a towing vehicle of ample capacity. Refer to the documentation of the towing vehicle.
  - 3 If the unit is to be backed up by the towing vehicle, disengage the overrun brake mechanism (if it is not an automatic mechanism).
  - 4 Never exceed the maximum towing speed of the unit (mind the local regulations).
  - 5 Place the unit on level ground and apply the parking brake before disconnecting the unit from the towing vehicle. Unclip the safety break-away cable or safety chain. If the unit has no parking brake or jockey wheel, immobilize the unit by placing chocks in front of and/or behind the wheels. When the tow bar can be positioned vertically, the locking device must be applied and kept in good order. The unit must always be used/parked/stored in a non publicly accessible area, locked away from access by unauthorized persons.
  - 6 To lift heavy parts, a hoist of ample capacity, tested and approved according to local safety regulations, shall be used.
  - 7 Lifting hooks, eyes, shackles, etc., shall never be bent and shall only have stress in line with their design load axis. The capacity of a lifting device diminishes when the lifting force is applied at an angle to its load axis.
  - 8 For maximum safety and efficiency of the lifting apparatus all lifting members shall be applied as near to perpendicular as possible. If required, a

lifting beam shall be applied between hoist and load.

- 9 Never leave a load hanging on a hoist.
- 10 A hoist has to be installed in such a way that the object will be lifted perpendicular. If that is not possible, the necessary precautions must be taken to prevent load-swinging, e.g. by using two hoists, each at approximately the same angle not exceeding 30° from the vertical.
- 11 Locate the unit away from walls. Take all precautions to ensure that hot air exhausted from the engine and driven machine cooling systems cannot be recirculated. If such hot air is taken in by the engine or driven machine cooling fan, this may cause overheating of the unit; if taken in for combustion, the engine power will be reduced.
- 12 Before moving the compressor, switch it off.
- 13 If the warning light on the ABS module or in the vehicle lights up, please contact Atlas Copco.

## **SAFETY DURING USE AND OPERATION**

- 1 When the unit has to operate in a fire-hazardous environment, each engine exhaust has to be provided with a spark arrester to trap incendiary sparks.
- 2 The exhaust contains carbon monoxide which is a lethal gas. When the unit is used in a confined space, conduct the engine exhaust to the outside atmosphere by a pipe of sufficient diameter; do this in such a way that no extra back pressure is created for the engine. If necessary, install an extractor. Observe any existing local regulations. Make sure that the unit has sufficient air intake for operation. If necessary, install extra air intake ducts.

- 3 When operating in a dust-laden atmosphere, place the unit so that dust is not carried towards it by the wind. Operation in clean surroundings considerably extends the intervals for cleaning the air intake filters and the cores of the coolers.
- 4 Close the compressor air outlet valve before connecting or disconnecting a hose. Ascertain that a hose is fully depressurized before disconnecting it. Before blowing compressed air through a hose or air line, ensure that the open end is held securely, so that it cannot whip and cause injury.
- 5 The air line end connected to the outlet valve must be safeguarded with a safety cable, attached next to the valve.
- 6 No external force may be exerted on the air outlet valves, e.g. by pulling on hoses or by installing auxiliary equipment directly to a valve, e.g. a water separator, a lubricator, etc. Do not step on the air outlet valves.
- 7 Never move a unit when external lines or hoses are connected to the outlet valves, to avoid damage to valves, manifold and hoses.
- 8 Do not use compressed air from any type of compressor, without taking extra measures, for breathing purposes as this may result in injury or death. For breathing air quality, the compressed air must be adequately purified according to local legislation and standards. Breathing air must always be supplied at stable, suitable pressure.
- 9 Distribution pipework and air hoses must be of correct diameter and suitable for the working pressure. Never use frayed, damaged or deteriorated hoses. Replace hoses and flexibles before the lifetime expires. Use only the correct type and size of hose end fittings and connections.
- 10 If the compressor is to be used for sand-blasting or will be connected to a common compressed-air system, fit an appropriate non-return valve (check valve) between compressor outlet and the connected sand-blasting or compressed-air system. Observe the right mounting position/direction.
- 11 Before removing the oil filler plug, ensure that the pressure is released by opening an air outlet valve.
- 12 Never remove a filler cap of the cooling water system of a hot engine. Wait until the engine has sufficiently cooled down.
- 13 Never refill fuel while the unit is running, unless otherwise stated in the Atlas Copco Instruction Book (AIB). Keep fuel away from hot parts such as air outlet pipes or the engine exhaust. Do not smoke when fuelling. When fuelling from an automatic pump, an earthing cable should be connected to the unit to discharge static electricity. Never spill nor leave oil, fuel, coolant or cleansing agent in or around the unit.
- 14 All doors shall be shut during operation so as not to disturb the cooling air flow inside the bodywork and/or render the silencing less effective. A door should be kept open for a short period only e.g. for inspection or adjustment.
- 15 Periodically carry out maintenance works according to the maintenance schedule.
- 16 Stationary housing guards are provided on all rotating or reciprocating parts not otherwise protected and which may be hazardous to personnel. Machinery shall never be put into operation, when such guards have been removed, before the guards are securely reinstalled.
- 17 Noise, even at reasonable levels, can cause irritation and disturbance which, over a long period of time, may cause severe injuries to the nervous system of human beings. When the sound pressure level, at any point where personnel normally has to attend, is:
  - below 70 dB(A): no action needs to be taken,
  - above 70 dB(A): noise-protective devices should be provided for people continuously being present in the room,
  - below 85 dB(A): no action needs to be taken for occasional visitors staying a limited time only,
  - above 85 dB(A): room to be classified as a noise-hazardous area and an obvious warning shall be placed permanently at each entrance to alert people entering the room, for even relatively short times, about the need to wear ear protectors,
  - above 95 dB(A): the warning(s) at the entrance(s) shall be completed with the recommendation that also occasional visitors shall wear ear protectors,
  - above 105 dB(A): special ear protectors that are adequate for this noise level and the spectral composition of the noise shall be provided and a special warning to that effect shall be placed at each entrance.
- 18 The unit has parts, which may be accidentally touched by personnel, of which the temperature can be in excess of 80 °C (176 °F). The insulation or safety guard, protecting these parts shall not be removed before the parts have cooled down to room temperature.
- 19 Never operate the unit in surroundings where there is a possibility of taking in flammable or toxic fumes.

- 20 If the working process produces fumes, dust or vibration hazards, etc., take the necessary steps to eliminate the risk of personnel injury.
- 21 When using compressed air or inert gas to clean down equipment, do so with caution and use the appropriate protection, at least safety glasses, for the operator as well as for any bystander. Do not apply compressed air or inert gas to your skin or direct an air or gas stream at people. Never use it to clean dirt from your clothes.
- 22 When washing parts in or with a cleaning solvent, provide the required ventilation and use appropriate protection such as a breathing filter, safety glasses, rubber apron and gloves, etc.
- 23 Safety shoes should be compulsory in any workshop and if there is a risk, however small, of falling objects, wearing of a safety helmet should be included.
- 24 If there is a risk of inhaling hazardous gases, fumes or dust, the respiratory organs must be protected and depending on the nature of the hazard, so must the eyes and skin.
- 25 Remember that where there is visible dust, the finer, invisible particles will almost certainly be present too; but the fact that no dust can be seen is not a reliable indication that dangerous, invisible dust is not present in the air.
- 26 Never operate the unit at pressures or speeds below or in excess of its limits as indicated in the technical specifications.

## **SAFETY DURING MAINTENANCE AND REPAIR**

Maintenance, overhaul and repair work shall only be carried out by adequately trained personnel; if required, under supervision of someone qualified for the job.

- 1 Use only the correct tools for maintenance and repair work, and only tools which are in good condition.
- 2 Parts shall only be replaced by genuine Atlas Copco replacement parts.
- 3 All maintenance work, other than routine attention, shall only be undertaken when the unit is stopped. Steps shall be taken to prevent inadvertent starting. In addition, a warning sign bearing a legend such as "work in progress; do not start" shall be attached to the starting equipment. On engine-driven units the battery shall be disconnected and removed or the terminals covered by insulating caps. On electrically driven units the main switch shall be locked in open position and the fuses shall be taken out. A warning sign bearing a legend such as "work in progress; do not supply voltage" shall be attached to the fuse box or main switch.
- 4 Before dismantling any pressurized component, the compressor or equipment shall be effectively isolated from all sources of pressure and the entire system shall be relieved of pressure. Do not rely on non-return valves (check valves) to isolate pressure systems. In addition, a warning sign bearing a legend such as "work in progress; do not open" shall be attached to each of the outlet valves.
- 5 Prior to stripping an engine or other machine or undertaking major overhaul on it, prevent all movable parts from rolling over or moving.

- 6 Make sure that no tools, loose parts or rags are left in or on the machine. Never leave rags or loose clothing near the engine air intake.
- 7 Never use flammable solvents for cleaning (fire-risk).
- 8 Take safety precautions against toxic vapours of cleaning liquids.
- 9 Never use machine parts as a climbing aid.
- 10 Observe scrupulous cleanliness during maintenance and repair. Keep away dirt, cover the parts and exposed openings with a clean cloth, paper or tape.
- 11 Never weld on or perform any operation involving heat near the fuel or oil systems. Fuel and oil tanks must be completely purged, e.g. by steam-cleaning, before carrying out such operations. Never weld on, or in any way modify, pressure vessels. Disconnect the alternator cables during arc welding on the unit.
- 12 Support the tow bar and the axle(s) securely if working underneath the unit or when removing a wheel. Do not rely on jacks.
- 13 Do not remove any of, or tamper with, the sound-damping material. Keep the material free of dirt and liquids such as fuel, oil and cleansing agents. If any sound-damping material is damaged, replace it to prevent the sound pressure level from increasing.
- 14 Use only lubricating oils and greases recommended or approved by Atlas Copco or the machine manufacturer. Ascertain that the selected lubricants comply with all applicable safety regulations, especially with regard to explosion or fire-risk and the possibility of decomposition or generation of hazardous gases. Never mix synthetic with mineral oil.

- 15 Protect the engine, alternator, air intake filter, electrical and regulating components, etc., to prevent moisture ingress, e.g. when steam-cleaning.
- 16 When performing any operation involving heat, flames or sparks on a machine, the surrounding components shall first be screened with non-flammable material.
- 17 Never use a light source with open flame for inspecting the interior of a machine.
- 18 Disconnect –battery-clamp before starting electrical servicing or welding (evt. turn battery-switch in “off” position).
- 19 When repair has been completed, the machine shall be barred over at least one revolution for reciprocating machines, several revolutions for rotary ones to ensure that there is no mechanical interference within the machine or driver. Check the direction of rotation of electric motors when starting up the machine initially and after any alteration to the electrical connection(s) or switch gear, to check that the oil pump and the fan function properly.
- 20 Maintenance and repair work should be recorded in an operator’s logbook for all machinery. Frequency and nature of repairs can reveal unsafe conditions.
- 21 When hot parts have to be handled, e.g. shrink fitting, special heat-resistant gloves shall be used and, if required, other body protection shall be applied.
- 22 When using cartridge type breathing filter equipment, ascertain that the correct type of cartridge is used and that its useful service life is not surpassed.
- 23 Make sure that oil, solvents and other substances likely to pollute the environment are properly disposed of.
- 24 Before clearing the unit for use after maintenance or overhaul, check that operating pressures, temperatures and speeds are correct and that the control and shutdown devices function correctly.

### **TOOL APPLICATIONS SAFETY**

Apply the proper tool for each job. With the knowledge of correct tool use and knowing the limitations of tools, along with some common sense, many accidents can be prevented.

Special service tools are available for specific jobs and should be used when recommended. The use of these tools will save time and prevent damage to parts.

## SPECIFIC SAFETY PRECAUTIONS

### Batteries

When servicing batteries, always wear protecting clothing and glasses.

- 1 The electrolyte in batteries is a sulphuric acid solution which is fatal if it hits your eyes, and which can cause burns if it contacts your skin. Therefore, be careful when handling batteries, e.g. when checking the charge condition.
- 2 Install a sign prohibiting fire, open flame and smoking at the post where batteries are being charged.
- 3 When batteries are being charged, an explosive gas mixture forms in the cells and might escape through the vent holes in the plugs. Thus an explosive atmosphere may form around the battery if ventilation is poor, and can remain in and around the battery for several hours after it has been charged. Therefore:
  - never smoke near batteries being, or having recently been, charged,
  - never break live circuits at battery terminals, because a spark usually occurs.
- 4 When connecting an auxiliary battery (AB) in parallel to the unit battery (CB) with booster cables: connect the + pole of AB to the + pole of CB, then connect the - pole of CB to the mass of the unit. Disconnect in the reverse order.

### Pressure vessels

Maintenance/installation requirements:

- 1 The vessel can be used as pressure vessel or as separator and is designed to hold compressed air for the following application:
  - pressure vessel for compressor,
  - medium AIR/OIL,
  - and operates as detailed on the data plate of the vessel:
  - the maximum working pressure ps in bar (psi),
  - the maximum working temperature Tmax in °C (°F),
  - the minimum working temperature Tmin in °C (°F),
  - the capacity of the vessel V in l (US gal, Imp gal, cu.ft).
- 2 The pressure vessel is only to be used for the applications as specified above and in accordance with the technical specifications. Safety reasons prohibit any other applications.
- 3 National legislation requirements with respect to re-inspection must be complied with.
- 4 No welding or heat treatment of any kind is permitted to those vessel walls which are exposed to pressure.
- 5 The vessel is provided and may only be used with the required safety equipment such as manometer, overpressure control devices, safety valve, etc.
- 6 Draining of condensate shall be performed daily when vessel is in use.
- 7 Installation, design and connections should not be changed.
- 8 Bolts of cover and flanges may not be used for extra fixation.

- 9 (Pressure) vessel maintenance is to be performed by Atlas Copco.

### Safety valves

Operating & Maintenance

Only trained and technically competent personnel should consider overhaul, re-set or performance testing of safety valves.

The safety valve is supplied with either a lead security seal or crimped cover to deter unauthorised access to the pressure regulation device.

Under no circumstances should the set pressure of the safety valve be altered to a different pressure than that stamped on the valve without the permission of the installation designer.

If the set pressure must be altered then use only correct parts supplied by Seetru and in accordance with the instructions available for the valve type.

Safety valves must be frequently tested and regularly maintained.

The set pressure should be periodically checked for accuracy.

When fitted, the lifting device should be operated at pressures not less than 75% of the set pressure to ensure free and easy movement of internal parts.

The frequency of tests is influenced by factors such as the severity of the operating environment and aggressiveness of the pressurised medium.

Soft seals and springs should be replaced as part of the maintenance procedure.

Do not paint or coat the installed safety valve (see also **Preventive maintenance schedule for the compressor**).

# Leading particulars

## GENERAL DESCRIPTION

The XRY5 557 Cd - XRY5 1220 CD7 is a silenced, two-stage, oil-injected screw compressor, built for a nominal effective working pressure of 35 bar (510 psi).

The XRXS 567 Cd - XRXS 1240 CD7 and XRXS 607 Cd - XRXS 1275 CD7 are silenced, two-stage, oil-injected screw compressors, built for a nominal effective working pressure of 30 bar (435 psi).

The XRVS 617 Cd - XRVS 1300 CD7 and XRVS 647 Cd - XRVS 1350 CD7 are silenced, two-stage, oil-injected screw compressors, built for a nominal effective working pressure of 25 bar (365 psi).

### Engine

The compressors are driven by a 6 cylinder in-line liquid-cooled diesel engine.

The engine's power is transmitted to the compressor element through a heavy-duty coupling.

### Compressor

The compressor casing houses two screw-type rotors, mounted on ball and roller bearings. The male rotor, driven by the engine, drives the female rotor. The compressor delivers pulsation-free air.

Injected oil is used for sealing, cooling and lubricating purposes.

The XRXS and XRVS type compressors can be equipped with two different gears, resulting in different FAD (Free Air Delivery).

### Compressor oil system

The oil is boosted by air pressure. The system has no oil pump.

The oil is removed from the air, in the air/oil vessel at first by centrifugal force, secondly through the oil separator element.

The vessel is provided with an oil level indicator.

### Regulation

The compressor is provided with a single or dual pressure pneumatic regulating system and a blow-off valve which is integrated in the unloader assembly. The valve is closed during operation by air receiver pressure and opens by air receiver pressure via the compressor element when the compressor is stopped.

When the air consumption increases, the air receiver pressure will decrease and vice versa.

This receiver pressure variation is sensed by the regulating valve which, by means of control air to the unloader and an electronic engine speed regulator, matches the air output to the air consumption. The air receiver pressure is maintained between the pre-selected working pressure and the corresponding unloading pressure.

## Cooling system

The engine is provided with a liquid-cooler and intercooler and the compressor is provided with an oil cooler. (For available options see chapter **Available options**.)

The cooling air is generated by a fan, driven by the engine.

## Safety devices

A thermal shut-down sensor protects the compressor against overheating. The air receiver is provided with a safety valve.

The engine is equipped with low oil pressure and high coolant temperature shut-down sensors.

The electric system is equipped with a 24V main switch.

## Frame and axles

The compressor/engine unit is supported by rubber buffers in a spillage-free frame.

The standard compressor has a towbar with parking brakes.

## Bodywork

The bodywork has openings for the intake and outlet of cooling air and hinged doors for maintenance and service operations. The bodywork is internally lined with sound-absorbing material.

## Lifting beam

A lifting beam is accessible when a small door at the top is opened.

## Serial number

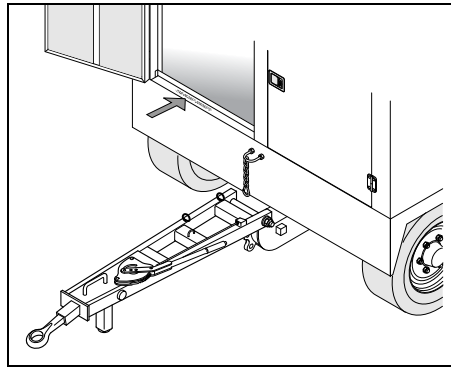

The serial number is stamped in at the front of the compressor on the upper edge of the frame behind the right door. It is also mentioned on the data plate and inside the control box.

## Control panel

The control panel grouping the air pressure gauge, control switch etc., is placed at the left hand/ rear end corner.

## Data plate

The compressor is furnished with a data plate showing the product code, the unit serial number and the working pressure (see chapter **Dataplate**).

# Main parts

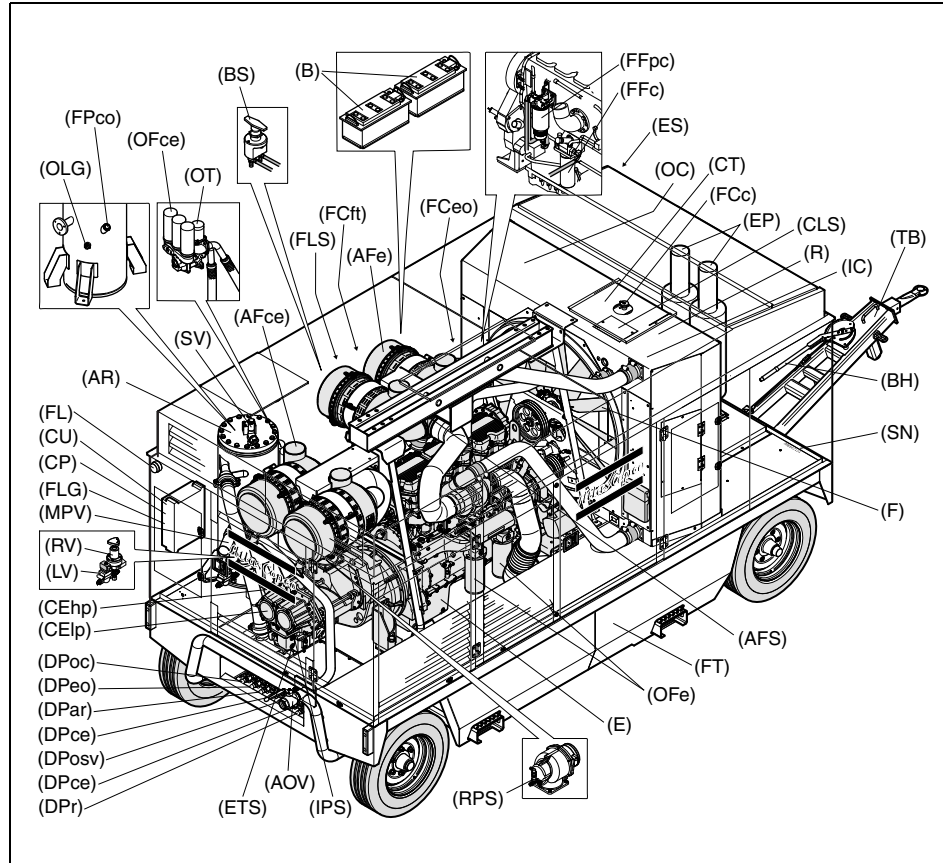



| Reference | Name                               |
|-----------|------------------------------------|
| AFce      | Air Filter (compressor element)    |
| AFe       | Air Filter (engine)                |
| AFS       | Air Filter Switch                  |
| AOV       | Air Outlet Valves                  |
| AR        | Air Receiver                       |
| ATS       | Ambient Temperature Sensor         |
| B         | Battery                            |
| BH        | Brake Handle                       |
| BS        | Battery Switch                     |
| CElp      | Compressor Element (low pressure)  |
| CEhp      | Compressor Element (high pressure) |
| CLS       | Coolant Level Switch               |
| CP        | Control Panel                      |
| CT        | Coolant Tank                       |
| CU        | Control Unit                       |
| DPar      | Drain Plug Air Receiver            |
| DPce      | Drain Plug Compressor Element      |
| DPeo      | Drain Plug Engine Oil              |
| DPoc      | Drain Plug Oil Cooler              |
| DPosv     | Drain Plug Oil Stop Valve          |
| DPr       | Drain Plug Radiator                |
| E         | Engine                             |
| EP        | Exhaust Pipe                       |

| Reference | Name                                 |
|-----------|--------------------------------------|
| ES        | Emergency Stop                       |
| ETS       | Element Temperature Sensor           |
| F         | Fan                                  |
| FCeo      | Filler Cap (engine oil)              |
| FCft      | Filler Cap (fuel tank)               |
| FCc       | Filler Cap (coolant)                 |
| FFpc      | Fuel Prefilter Caterpillar           |
| FFc       | Fuel Filter Caterpillar              |
| FL        | Flash Light                          |
| FLG       | Fuel Level Gauge                     |
| FLS       | Fuel Level Sensor                    |
| FPco      | Filler Plug (oil compressor element) |
| FT        | Fuel Tank                            |
| IC        | Intercooler                          |
| IPS       | Interstage Pressure Sensor           |
| LV        | Loading Valve                        |
| MPV       | Minimum Pressure Valve               |
| OC        | Oil Cooler                           |
| OFce      | Oil Filter (compressor element)      |
| OFe       | Oil Filter (engine)                  |
| OLG       | Oil Level Gauge                      |
| OT        | Oiltronix                            |
| R         | Radiator                             |

| Reference | Name                       |
|-----------|----------------------------|
| RPS       | Regulating Pressure Sensor |
| RV        | Regulating Valve           |
| SN        | Serial Number              |
| SV        | Safety Valve               |
| TB        | Towbar                     |
| WPS       | Working Pressure Sensor    |



| Reference | Name                       |
|-----------|----------------------------|
| RPS       | Regulating Pressure Sensor |
| RV        | Regulating Valve           |
| SC        | Safety Cartridge           |
| SL        | Scavenge Line              |
| SV        | Safety Valve               |
| TBV       | Thermostatic Bypass Valve  |
| TS        | Temperature Sensor         |
| TV        | Throttle Valve             |
| UA        | Unloader Assembly          |
| VV        | Vacuator Valve             |
| WPS       | Working Pressure Sensor    |

## AIR FLOW

Air drawn through the airfilter (AFce) into the compressor element (CElp CEhp) is compressed. At the element outlet, compressed air and oil pass into the air receiver/oil separator (AR/OS).

The check valve (CV) prevents blow-back of compressed air when the compressor is stopped. In the air receiver/oil separator (AR/OS), most of the oil is removed from the air/oil mixture.

The oil collects in the receiver and on the bottom of the separator element.

The air leaves the receiver via a minimum pressure valve (MPV) which prevents the receiver pressure from dropping below the minimum working pressure, even when the air outlet valves are open (specified in section **Limitations**). This ensures adequate oil injection and prevents oil consumption. The minimum pressure valve (MPV) also functions as a check valve.

The system comprises temperature sensors (TS), pressure sensors (PS) and a working pressure sensor (WPS).

## OIL SYSTEM

The lower part of the air receiver (AR) serves as oil tank.

Air pressure forces the oil from the air receiver/oil separator (AR/OS) through the oil cooler (OC), the oil filters (OF) and the oil stop valve (OSV) to the compressor element (CElp CEhp).

When the compressor is stopped and / or there is no pressure in the system, the oil stop valve (OSV) prevents the oil from flowing back into the compressor element.

The thermostatic by-pass valve (TBV) starts opening when the oil temperature is 80°C (176°F) (when no Oiltronix is installed). With installed Oiltronix, the thermostatic by-pass valve starts opening when the oil temperature is 40°C (104°F).

The compressor element has an oil gallery in the bottom of its casing. The oil for rotor lubrication, cooling and sealing is injected through holes in the gallery.

Lubrication of the bearings is ensured by oil injected into the bearing housings.

The injected oil, mixed with the compressed air, leaves the compressor element and re-enters the air receiver, where it is separated from the air as described in section **Air flow**. The oil that collects in the bottom of the oil separator element is returned to the system through a scavenging line (SL), which is provided with a flow restrictor (FR).

The oil filter by-pass valve opens when the pressure drop over the filter is above normal because of a clogged filter. The oil then by-passes the filter without being filtered. For this reason, the oil filter must be replaced at regular intervals (see section **Preventive maintenance schedule for the compressor**).

**PNEUMATIC REGULATING SYSTEM**

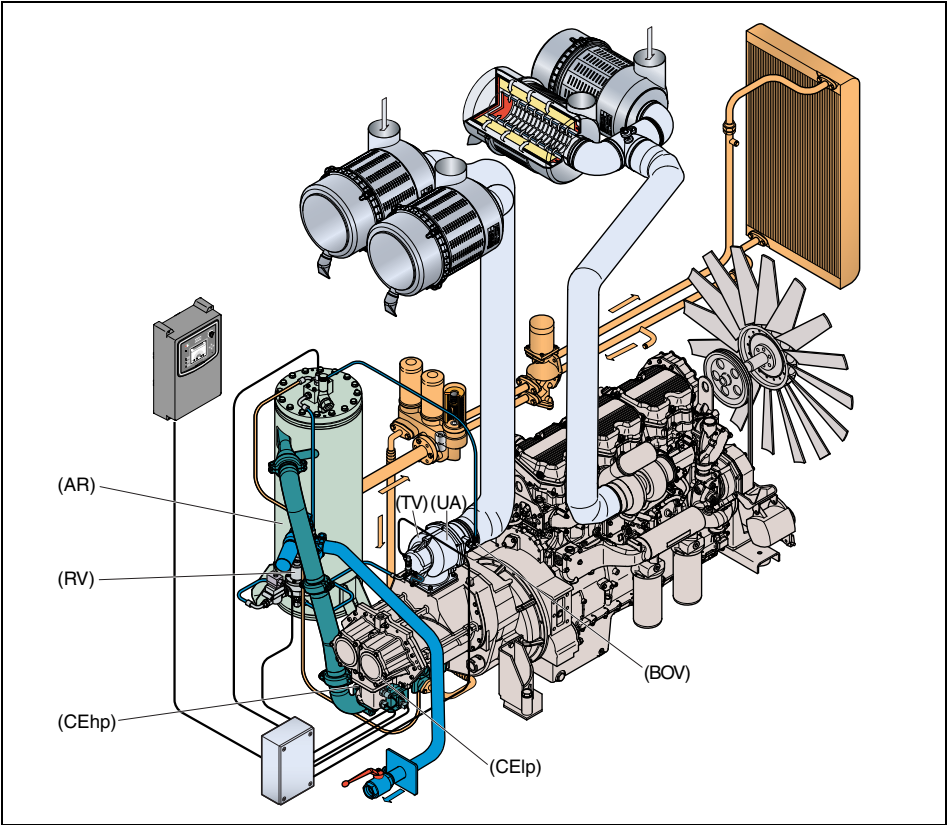

The compressor is provided with a pneumatic regulating system and a blow-off valve (BOV) which is integrated in the unloader assembly (UA). The valve is closed during operation by outlet pressure of the compressor element and opens by air receiver pressure when the compressor is stopped.

When the air consumption increases, the air receiver pressure will decrease and vice versa. This receiver pressure variation is sensed by the regulating valve (RV) which, by means of control air to the unloader assembly (UA), matches the air output to the air consumption. The air receiver pressure is maintained between the pre-selected working pressure and the corresponding unloading pressure.

When starting the compressor, the throttle valve (TV) is kept closed via receiver pressure. The compressor element (CElp CEhp) takes in air and pressure builds up in the receiver (AR). The throttle valve (TV) is closed. The air output is controlled from maximum output (100%) to no output (0%) by:

1. Speed control of the engine between maximum load speed and unloading speed (the output of a screw compressor is proportional to the rotating speed).
2. Air inlet throttling.

If the air consumption is equal to or exceeds the maximum air output, the engine speed is held at maximum load speed and the throttle valve (TV) is fully open.

If the air consumption is less than the maximum air output, air receiver pressure increases and the regulating valve supplies control air to throttle valve (TV) to reduce the air output and holds air receiver pressure between the normal working pressure and the corresponding unloading pressure. Unloading pressure = normal working pressure + 1 bar (14.504 psi).

When the air consumption is resumed, the blow off valve (BOV) closes and the throttle valve (TV) gradually opens the air intake and the electronic speed regulator increases the engine speed.

The construction of the regulating valve (RV) is such that any increase (decrease) of the air receiver pressure above the pre-set valve opening pressure results in a proportional increase (decrease) of the control pressure to the throttle valve and the electronic speed regulator.

Part of the control air is vented to atmosphere, and any condensate discharged, through the vent holes.



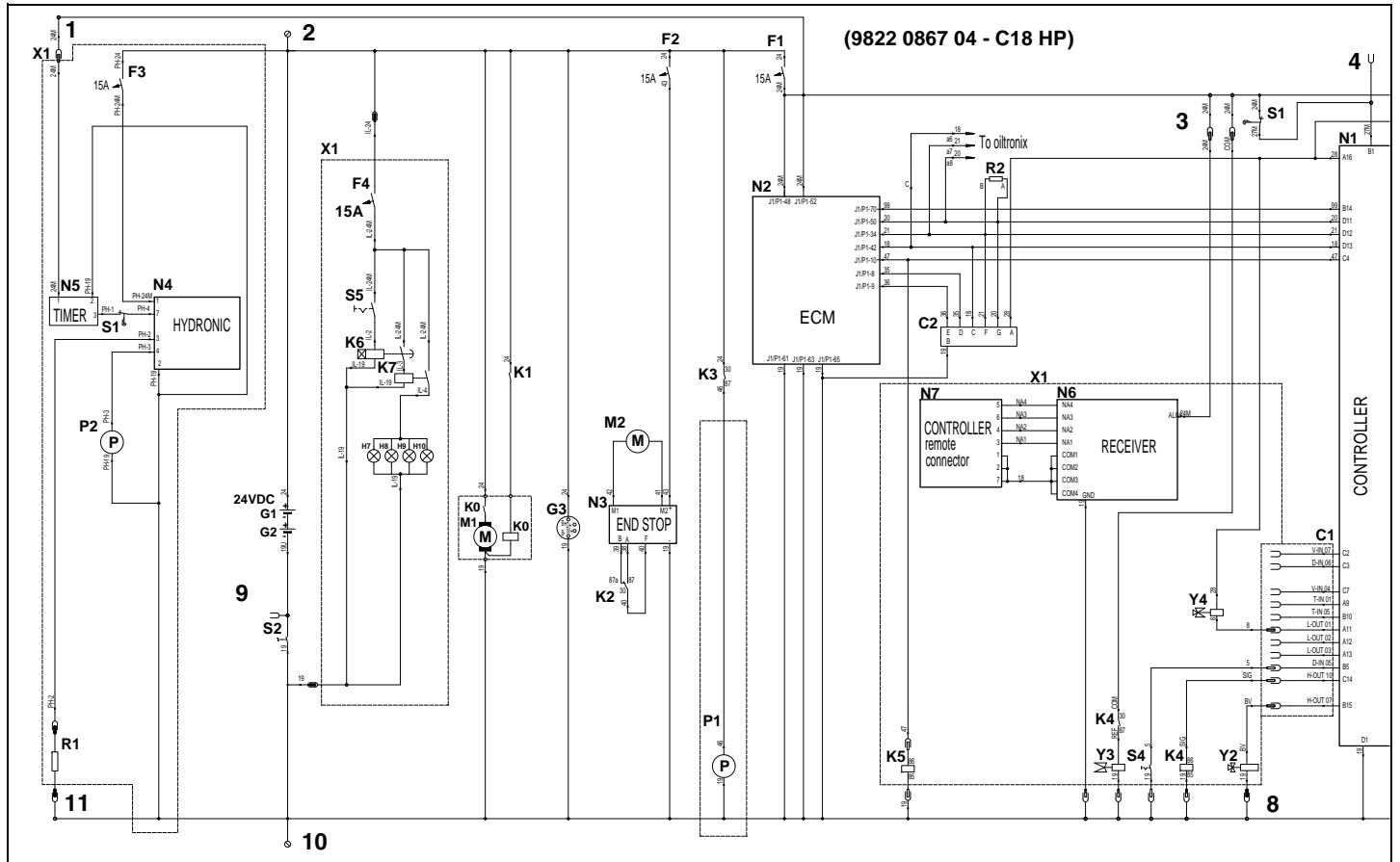

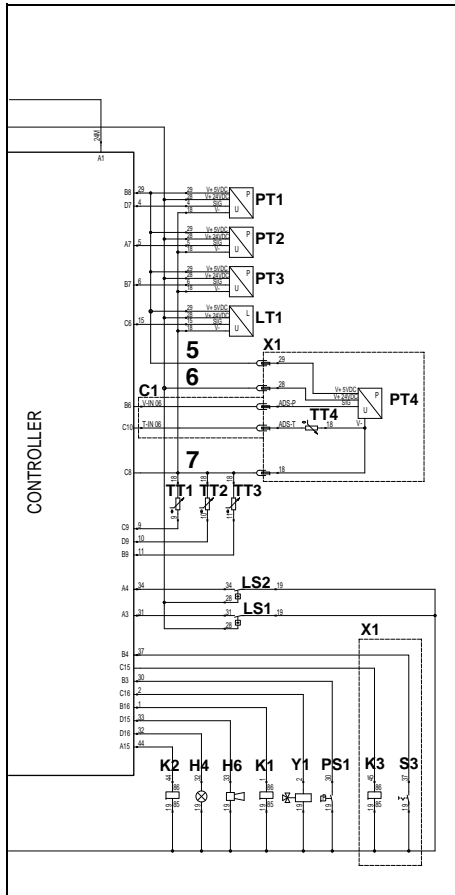







# ELECTRIC SYSTEM























|        |  |           |  |
|--------|--|-----------|--|
| C1     | Spare I/O (female contacts)                | PT4       | Pressure sensor, Aftercooler                                   |
| C2     | CAT engine service tool connector          | R1        | Resistor 470 Ohm 3W  |
| F1     | Fuse 15A                                   | R2        | Termination resistor 120 Ohm                                   |
| F2     | Fuse 15A, roof                             | S1        | Emergency Stop   |
| F3     | Fuse 15A, preheater                        | S2        | Battery switch   |
| F4     | Fuse 15A, internal lights                  | S3        | Fuel supply selector switch                                    |
| G1     | Battery                                    | S4        | Dual pressure selector switch                                  |
| G2     | Battery                                    | S5        | Internal lights switch   |
| G3     | Alternator                                 | TT1       | Temperature sensor, PT1000, LP Element temperature             |
| H4     | Warning flasher light                      | TT2       | Temperature sensor, PT1000, HP element temperature             |
| H6     | Horn                                       | TT3       | Temperature sensor, PT1000, Ambient temperature                |
| H7-H10 | Internal lights                            | TT4       | Temperature sensor, PT1000, Aftercooler                        |
| K0     | Relay, Starter motor                       | Y1        | Loading Valve  |
| K1     | Relay, Aux. starter                        | Y2        | Blow-off valve   |
| K2     | Relay, Roof actuator                       | Y3        | Air shut-off valve   |
| K3     | Relay, Refuelling pump                     | Y4        | Dual pressure valve  |
| K4     | Relay, Refinery equipment                  | X1        | Optional equipment   |
| K5     | Relay, Ether start                         |           |  |
| K6     | Timer relay                                |           |  |
| K7     | Relay                                      |           |  |
| LS1    | Level Switch, Coolant level Warning        | <b>1</b>  | Fused 24 VDC for Spare I/O's and options                       |
| LS2    | Level Switch, Coolant level Shutdown       | <b>2</b>  | 24 VDC (power supply box) for Spare I/O's and options          |
| LT1    | Level sensor, Fuel level                   | <b>3</b>  | Fused 24 VDC for Spare I/O's and options                       |
| M1     | Starter motor                              | <b>4</b>  | Fused 24 VDC after Emergency Stop for Spare I/O's and options  |
| M2     | Roof actuator                              | <b>5</b>  | 5 VDC for Spare I/O's and options                              |
| N1     | Compressor Control Module                  | <b>6</b>  | Power After Contact for Spare I/O's and options                |
| N2     | Engine Control Module (Caterpillar)        | <b>7</b>  | Digital Ground for Spare I/O's and options                     |
| N3     | Roof actuator controller                   | <b>8</b>  | Switched Ground for Spare I/O's and options                    |
| N4     | Hydronic heater                            | <b>9</b>  | Unswitched Ground  |
| N5     | Timer                                      | <b>10</b> | Switched Ground (power supply box) for Spare I/O's and options |
| N6     | Receiver wireless remote control           | <b>11</b> | Switched Ground for Spare I/O's and options                    |
| N7     | Compressor control module remote connector |           |  |
| P1     | Refuelling pump                            |           |  |
| P2     | Fuel pump preheater                        |           |  |
| PS1    | Pressure Switch, Airfilter                 |           |  |
| PT1    | Pressure sensor, Vessel pressure           |           |  |
| PT2    | Pressure sensor, Regulating Pressure       |           |  |
| PT3    | Pressure sensor, Interstage pressure       |           |  |

## MARKINGS AND INFORMATION LABELS

|   |  |
|---|--|
|                   | Dangerous outlet gases.                                    |
|                   | Danger, hot surface.                                       |
|                   | Electrocution hazard.                                      |
|  PAROIL S         | Atlas Copco synthetic compressor oil.                      |
|  PAROIL SAE 15W40 | Atlas Copco mineral engine oil.                            |
|                   | Manual.  |
|                   | Read the instruction manual before working on the battery. |
|                   | Reset fuse.  |
|                   | On / off button.   |
|                   | Prohibition to open air valves without connected hoses.    |
|                   | Rotation direction.  |
|                   | Inlet.   |

|   |  |
|---|--|
|  | Outlet.  |
|  | Compressor oil drain.  |
|  | Read the instruction manual before starting.                                     |
|  | Service every 24 hours.  |
|  | Warning! Part under pressure.  |
|  | Do not stand on outlet valves.   |
|  | Start-Stop indication of switch.   |
|  | Do not run the compressor with open doors.                                       |
|  | Lifting permitted.   |
|  | Use diesel fuel only.  |
| <b>9.5 bar<br/>(138 psi)</b>  | Tyre pressure.   |
|  | Sound power level in accordance with Directive 2000/14/EC (expressed in dB (A)). |

|   |   |
|---|---|
|  | Fork lifting permitted.   |
|  | Don't lift here.  |
|  | Read the instruction manual before lifting.                               |
|  | Filler cap coolant.   |
|  | Read the instruction manual before topping up with coolant.               |
|  | Service point.  |
|  | Circuit breaker.  |
|  | Do not run the compressor when the baffles are not in the right position. |



# Operating instructions

## PARKING, TOWING AND LIFTING INSTRUCTIONS

### Safety precautions



The operator is expected to apply all relevant Safety precautions.

### Attention



Before putting the compressor in to use, check the brake system as described in section Brake adjustments.

After the first 100 km travel:

Check and retighten the wheel nuts and towbar bolts to the specified torque. See section Torque values.

Check the brake adjustment. See section Brake adjustments.



When towing, lifting or transporting the compressor in any way, the battery switch must always be in the “OFF” position!

Also switch off the preheater as this unit is directly connected to the batteries.

## PARKING INSTRUCTIONS WAGON

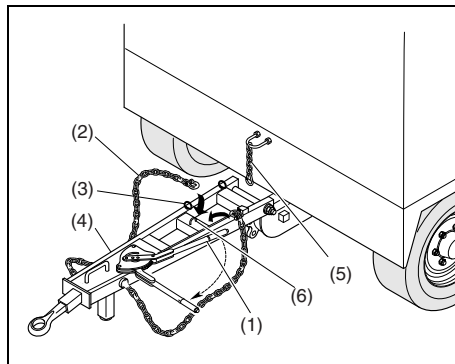

Uncouple vehicle.

Apply parking brake by moving the lever (1) in the direction of the arrow.

Connect the safety chain (2) to the eyes (3) on the towbar (4). You can move the towbar (4) upwards and secure it by connecting the chain (5) to the eye (6).

Place the compressor as level as possible; however, it can be operated temporarily in an out-of-level position not exceeding 15°. If the compressor is parked on sloping ground, immobilize the compressor by placing wheel chocks (available as option) in front of or behind the wheels.

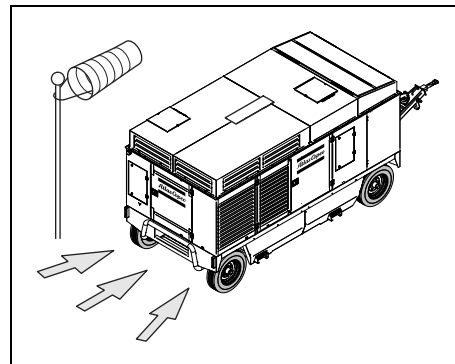

Locate the rear-end of the compressor upwind, away from contaminated wind-streams and walls. Avoid recirculation of exhaust air from the engine. This can cause overheating and engine power decrease.

## TOWING INSTRUCTIONS WAGON

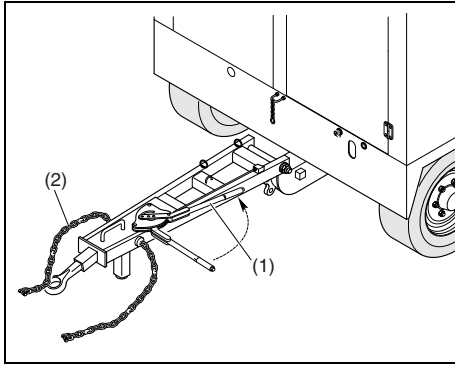

**Before towing the compressor, ensure that the towing equipment of the vehicle matches the towing eye. The height of the towing device of the vehicle must be 815 - 845 mm (31.8 - 33 in).**

1. Attach the compressor to the towing vehicle.
2. Move hand brake lever (1) in the direction of the arrow till stop and connect the breakaway chain (2) to the towing vehicle.

Never move the compressor with air hoses connected to the air outlet valves.



**Before moving the compressor, switch it off.**

## TOWBAR LEVELLING WAGON

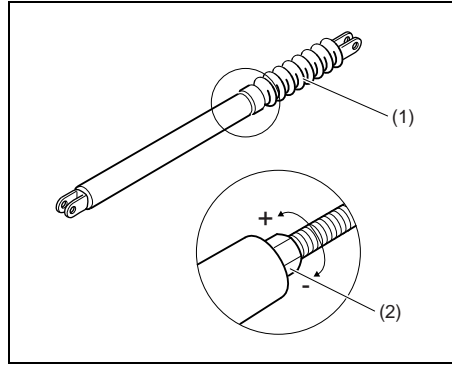

The towbar of the wagon is equipped with an adjustable spring loaded levelling device.

To adjust:

1. Slide back the rubber bellows (1).
2. Turn the nut (2) clockwise to increase the spring load for lifting the towbar; turn the nut (2) counter clockwise to decrease the spring load for lowering the towbar.
3. Slide the bellows (1) over the nut.

## LIFTING INSTRUCTIONS

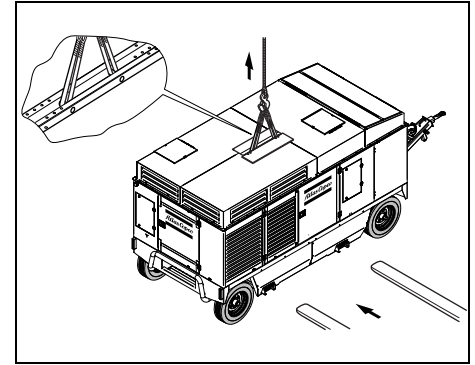

To lift the compressor, use a lift truck or crane with sufficient capacity (weight: see indication on **Dataplate**).

See to it that the compressor will be lifted vertically and remains level.



**Lifting acceleration and retardation must be kept within safe limits (max. 2xg).**

**Helicopter lifting is not allowed.**

**Lifting is not allowed when the unit is running.**

## INTERNAL LIGHTING

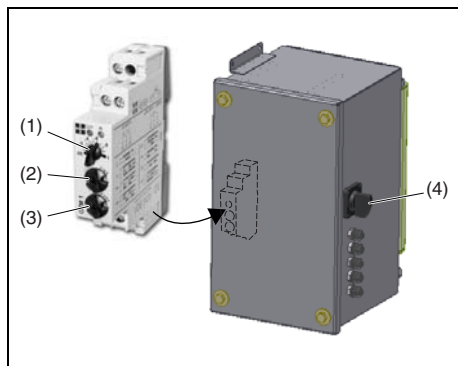

The internal lighting circuit is equipped with a timer. When the internal lighting is switched on with switch (4), the timer is started. After a preset time the internal light will be switched off automatically.

The timer is set by choosing a range with button (2) (default: 1 h) and setting a factor with button (1) (default: 0,2). This results in a lighting time of 12 minutes.



**Do not change the setting of button (3).**

## PREHEATER (OPTION)



**Before performing any maintenance jobs always switch off the preheater and remove the fuse or disconnect the heater from the battery.**

## DESCRIPTION HEATING OPERATION

When switched on the signal lamp in the mini-clock control element is lit. The waterpump starts and after a fixed programme with prerinsing and preheating, combustion air fan, glow plug and fuel dosing pump set combustion going. Once a stable flame has formed, the glow plug is switched off by a timer.

Depending on the heat requirement, the heater will switch between three levels, LARGE, SMALL and OFF (control interval). The temperature thresholds have been fixed programmed in the electronic control device. If the heat requirement at level SMALL is so low that the cooling water temperature reaches 85°C (185°F), the device goes into control interval. This is followed by the fan continuing to run for about 130 sec. The signal lamp will stay lit during the control interval and also the waterpump continues to run.

If the heater does not ignite within 90 seconds after fuel pumping has started, the start procedure must be repeated. If the heater once again fails to ignite after 90 seconds a fault shut down is effected.

It is possible to override a fault shut-down by briefly switching the heater off and then on again.



**Do not repeat this more than twice in succession!**

When an emergency stop has to be performed:

- Switch off the preheater at the control element
- Remove the fuse or disconnect the heater from the battery

## Safety procedure before starting after a longer period of standstill

- Check whether the fuse is in its place and / or the wiring is connected to the battery.
- Check if all parts are firmly fixed.
- Check the fuel system visually on leaks.

## Preheater altitude capability

- Up to 1,500 meters:  
no restrictions
- Above 1,500 meters:  
Operation possible for short periods  
Continuous operation NOT possible

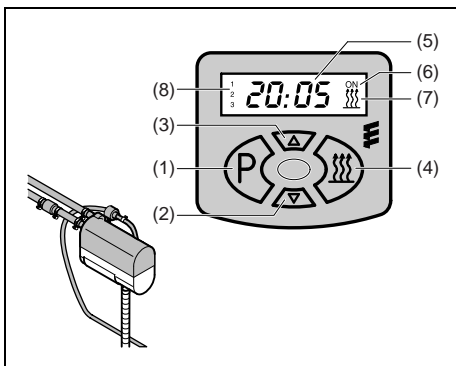

| Reference | Name                                |
|-----------|-------------------------------------|
| 1         | Button Mode                         |
| 2         | Button Time down                    |
| 3         | Button Time up                      |
| 4         | Button ON/OFF select pre-set time   |
| 5         | Time, pre-set time and heating time |
| 6         | Symbol pre-set time is active       |
| 7         | Symbol heating ON                   |
| 8         | Symbol pre-set time 1, 2 or 3       |

## General

- When no button is pressed the display will return to its default mode - normal time display.
- When setting the time, holding the buttons (2) or (3) pressed, the time will change more rapidly.
- With this mini-clock you can set and activate three pre-set times. Each pre-set time is deactivated after the set heating period has ended. It has to be activated again for each new heating action.

## Settings

### Commissioning

- After connecting the power all symbols in the display will blink. Now the actual time has to be set before the heater can be operated.
- Press button (1); time blinks. Set time with buttons (2) or (3).
- Press button (1); time is displayed, colon blinks.

### Setting the time

- Press button (1) longer then 3 sec.; time blinks. Set with buttons (2) or (3). Briefly press button (1); time is displayed, colon blinks.



**If you do not press the button within 5 seconds the mode is changed to "setting heating period".**

### Setting heating period

- Press button (1) longer then 3 sec.; time blinks. Wait till the display indicates "setting heating period"; heating symbol and time blink. Set heating period (10 to 120 min) using button (2) or (3). Press button (1); time is displayed, colon blinks.

## Setting pre-settings

- By pressing button (1) once, twice or three times you will select pre-set time 1, 2 or 3.
- The display shows e.g. pre-set time 1 and symbol 1. Set the pre-set period with buttons (2) or (3).
- With button (4) you can activate or deactivate the pre-set period. When activated the symbol "ON" appears and the symbol "1, 2 or 3".

## Operation

### Switching ON the heater

- Press button (4). The heating period lasts ..minutes. The display shows: remaining heating time and symbol 7.

### Switching OFF the heater

- Press button (4). The heater will run idle for about 3 minutes. The display shows: actual time.

### Continuous operation

- Press and hold button (3), then press button (4); now the heater will be operating till button (4) (heater off) is pressed.

### Activating/ deactivating pre-set time

- Select pre-set time 1, 2 or 3 by pressing button (1).
- Activate the selected time by pressing button (4).
- The display shows: symbol "ON" as well as the selected pre-set time, "1, 2 or 3".

## BEFORE STARTING

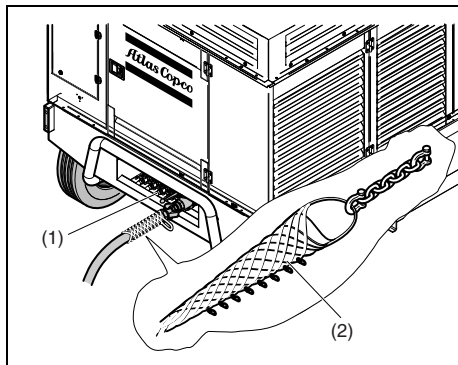

1. Before initial start-up, prepare battery for operation if not already done. See section **Recharging a battery**.
2. Check that the draining caps in the spillage-free frame are firmly tightened.
3. With the compressor standing level, check the level of the engine oil. Add oil, if necessary, to the upper mark on dipstick. Also check the engine coolant level. Consult the Engine Operation Manual for the type of coolant and type and viscosity grade of the engine oil.
4. Remove the air receiver drain plug (1), see figure, and open the valve to drain possible condensate. Close the valve when oil comes out and reinstall the drain plug. The interval between draining operations may be determined by experience, as the amount of condensate depends on the operating condition.



**Before draining, ensure that the pressure is released.**

5. Check the level of the compressor oil. See section **Check compressor oil level**. The pointer of oil level gauge (OLG) should register in the green range. Add oil if necessary. See section **Compressor oil** for the oil to be used.



**Before removing oil filler plug (FP), ensure that the pressure is released by opening an air outlet valve.**

6. Check that the fuel tank contains sufficient fuel. Top up, if necessary. Consult the Engine Operation Manual for the type of fuel.
7. Drain any water and sediment from the fuel filters until clean fuel flows from the drain cock.
8. Empty the dust trap of each air filter (AF). See section **Replacing the filter element and the safety cartridge**.
9. Clogged air filter(s) will be indicated on the display of the control panel, see section **Fault codes**. If indicated, replace the filter elements.
10. Check coolant level in engine coolant top tank integrated in radiator. Top up, if necessary. Consult the Engine Operation Manual for coolant specifications.
11. Attach the air line(s) to the closed air outlet valve(s).
12. Use hoses with suitable pressure rating and fit for the environmental conditions. Always install the pull relief (2), see figure. Inspect hoses and connections daily.



**No external force may be applied to the air outlet valve(s), e.g. by pulling hoses or by connecting equipment directly to the valve(s).**

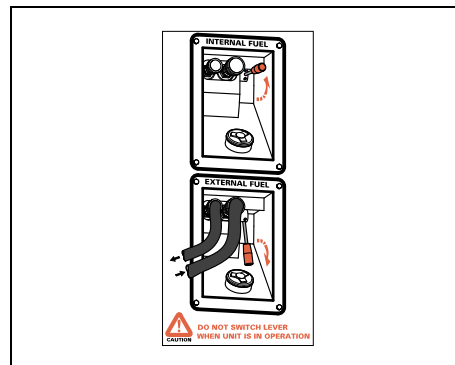

13. Select fuel supply mode.



**Do not switch the fuel selecting lever when the unit is in operation!**

- Internal supply.  
Move the lever of the fuel selection supply valve upwards.
- External supply.  
Connect the supply and return hose to the fuel nipples at the fuel funnel. Move the lever of the fuel selection supply valve downwards.

# Starting / Stopping

## Safety precautions



**Do not disconnect power supply to control box in any way when the control box is switched on. This will cause memory loss.**

**Do not switch off the circuit breaker when the control box is switched on. This will cause memory loss.**

Make sure the fuel tank is filled up when “INTERNAL FUEL” is selected.

## BATTERY SWITCH

The compressor is equipped with a battery switch.

When the compressor is not in use this switch must always be in the “OFF” position.

It is not allowed to use this switch as an emergency switch or for stopping the compressor. It will cause damage in the control unit when using this switch for stopping.









Always first shut off the control unit and wait until the display is dark before switching the battery switch to position “OFF”.





**Please be aware that the (optional) preheater unit is still “live” with the battery switch in “OFF” position.**

## CONTROL PANEL



| Reference  | Name   |
|--|--|
|  | <p>POWER OFF / ON switch<br/>To switch the control panel on and off</p>  |
|  | <p>START button<br/>Pressing this button will start the compressor.</p>  |
|  | <p>STOP button<br/>Pressing this button will stop the compressor in a controlled way.</p>  |
|  | <p>LOAD button. Pressing this button will:</p> <ul style="list-style-type: none"> <li>• initiate the Auto Load function, or commands the compressor to load (depending on actual status).</li> <li>• command the compressor to switch to Not Loaded (when in Load).</li> </ul> |
|  | <p>MEASUREMENTS VIEW button<br/>By pressing this button you can toggle between Measurements View and Main View.</p>  |
|  | <p>SETTINGS VIEW button<br/>By pressing this button you can toggle between Settings View and Main View.</p>  |
|  | <p>ALARMS VIEW button<br/>By pressing this button you can toggle between Alarms View and Main View.</p>  |
|  | <p>NAVIGATION buttons<br/>These buttons are used to navigate through the display menu's.</p>   |

|  |  |
|--|--|
|   | <p>ENTER button<br/>Confirms/stores the selection/change.</p>      |
|  | <p>BACK button<br/>Moves back one level or ignores the change.</p> |



## OPERATIONS OVERVIEW

It is possible to control the compressor locally with the Control Box, remotely with the remote switch inputs located on the back of the Control Box, or with software running on a PC with a CAN interface (PC Control Mode).

The way one ends up in each status can differ from how the Control Box is controlled, but the function of each status stays the same.

When reading this document, mind the difference between a status and a procedure. A status is a state in the Control Box's operation. A procedure is an action executed by the Control Box.

Example: The Stopping procedure is executed in the Stopping status, the Start Failure status and the Shutdown status.

### During operation



**The doors must be closed during operation and may be opened for short periods for inspection and adjustments only.**

### Regularly carry out following checks:

1. That the regulating valve (RV) is correctly adjusted, i.e. starts decreasing the engine speed when reaching the preset working pressure in the receiver.
2. Check the air outlet temperature of the compressor element.
3. Check the engine oil pressure, the coolant temperature and display of control box.
4. Avoid the engine running out of fuel. Nevertheless, if this happens, fill the fuel tank and prime the fuel system to speed up starting (see section **Overview icons**).

## BATTERY SWITCH

The compressor is equipped with a battery switch.

When the compressor is not in use this switch must always be in the "OFF" position.

It is not allowed to use this switch as an emergency switch or for stopping the compressor. It will cause damage in the control unit when using this switch for stopping.







Always first shut off the control unit and wait until the display is dark before switching the battery switch to position "OFF".

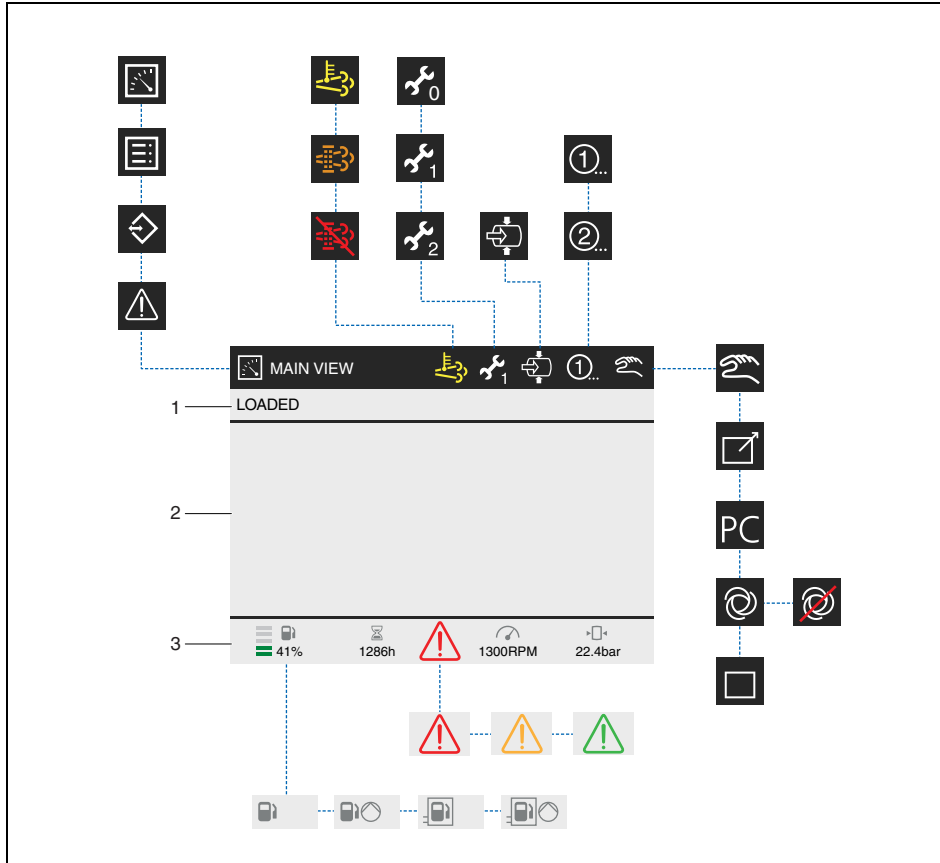

















**Please be aware that the (optional) preheater unit is still "live" with the battery switch in "OFF" position.**





## OVERVIEW ICONS



| Reference   | Name  |
|---|---|
| 1   | Compressor status   |
| 2   | Vessel pressure indication or info text   |
| 3   | Compressor info   |
|   |   |
|  | Main View Indication  |
|  | Measuring View Indication   |
|  | Settings View Indication  |
|  | Alarm View Indication   |
|  | DPF REGENERATION<br>High Exhaust System Temperature.<br>Means that the Diesel Particle Filter is being regenerated.         |
|  | DPF REGENERATION NEEDED<br>Means that the Diesel Particle Filter needs to be regenerated.<br>Please force DPF Regeneration. |

| Reference  | Name   |
|--|--|
|  | <b>DPF REGENERATION</b><br>Diesel Particle Filter Regeneration Inhibited.<br>Means that the DPF regeneration is inhibited, even if all criteria to activate a regeneration are met.                          |
|  | <b>OVERHAUL</b><br>Initial Overhaul required.  |
|  | <b>OVERHAUL</b><br>Minor Overhaul required.  |
|  | <b>OVERHAUL</b><br>Major Overhaul required.  |
|  | <b>AUTO LOAD</b><br>This icon will be shown if the Auto Load functionality is enabled, or by means of a parameter setting, or by means of pressing the load button before the machine is ready to be loaded. |
|  | <b>PRESET</b><br>Depending of which Pressure (and/ or Flow) setting is active, the controller will show its dedicated icon.  |
|  | <b>PRESET</b><br>Depending of which Pressure (and/ or Flow) setting is active, the controller will show its dedicated icon.  |

| Reference   | Name  |
|---|---|
|  | <b>OPERATION MODE</b><br>Local  |
|  | <b>OPERATION MODE</b><br>Remote   |
|  | <b>OPERATION MODE</b><br>PC Control   |
|  | <b>OPERATION MODE</b><br>Automatic  |
|  | <b>OPERATION MODE</b><br>Automatic Mode is active, but the Auto Start and Auto Stop function are both inactive. |
|  | <b>OPERATION MODE</b><br>Block Mode   |
|  | <b>ALARM</b><br>Active & not-acknowledged Shutdown Alarm.   |
|  | <b>ALARM</b><br>Active & not-acknowledged Non-Shutdown Alarm.   |
|  | <b>ALARM</b><br>Active & acknowledged Alarm.  |

| Reference   | Name   |
|---|--|
|  | <b>FUELTANK</b><br>Running at internal fueltank.   |
|  | <b>FUELTANK</b><br>Running at internal fueltank & Fuelpump is energized.                                       |
|  | <b>FUELTANK</b><br>Running at external fueltank, but internal fueltank level is shown.                         |
|  | <b>FUELTANK</b><br>Running at external fueltank, but internal fueltank level is shown & fuelpump is energized. |

## POSSIBLE VIEWS

### Main View

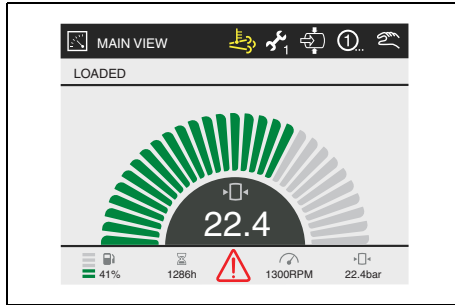

### Measuring View

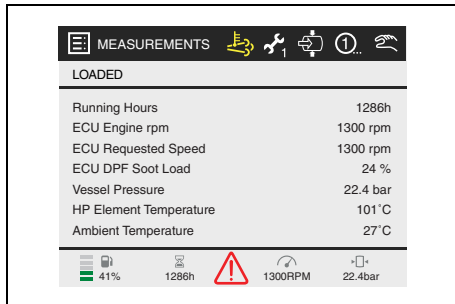

Use the Up and Down navigation buttons to scroll through the full list of measurements.

### Setup View

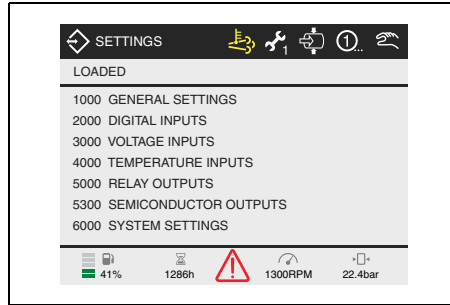

Use the Up and Down navigation buttons to scroll through the full list of settings.

Use the Enter button to enter the selected submenu.

Use the Back button to leave the entered (sub)menu.

### Alarm View

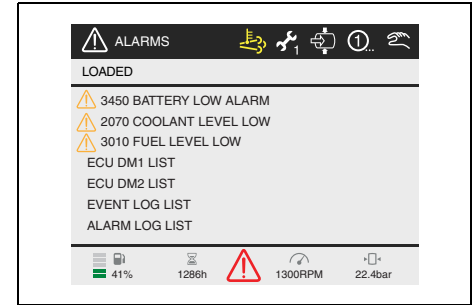

Use the Up and Down navigation buttons to scroll through the full list of alarms.

The DM Lists and the Log Lists can be selected and entered to access the sublist.

## STARTING

Switch on the battery switch.

Switch the controller on by switching the Power switch to the position "ON".

The instrument panel will now perform a selftest; the following display will be shown and the controller is initialized:

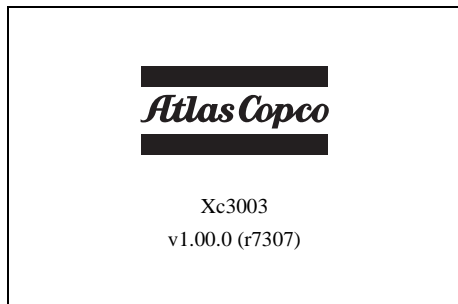

During initializing all buttons/inputs/outputs/alarms are inactive.

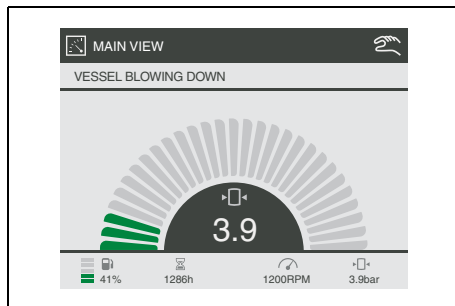

This view will be shown for about 2 seconds, after which the display will show the Main View.



The actual vessel pressure is shown. If the measured vessel pressure is higher than 1.5 bar, the unit will not start. The vessel pressure has to be lowered by opening the blow down valve. After power up, the vessel pressure normally is low enough to proceed with the starting procedure.





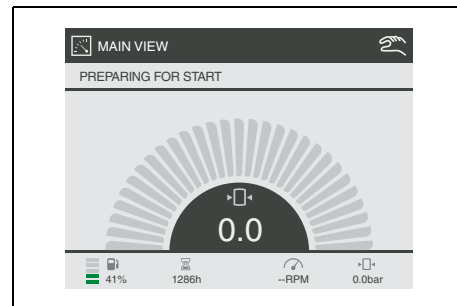

**If the Power switch is turned to the "OFF" position while the vessel is blowing down, it will not power down for as long as the vessel pressure is higher than 1.5 bar.**

| Active Buttons  |                         |
|---|-------------------------|
|  | Measurement View Button |
|  | Settings View Button    |
|  | Alarms View Button      |

The display now shows





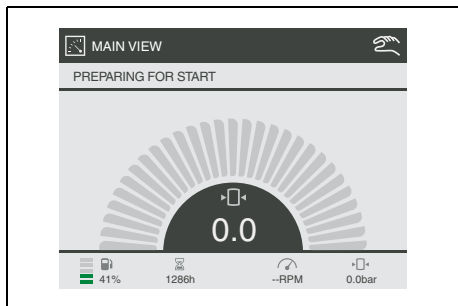

The machine is now ready to be started and is waiting for a start command.

| Active Buttons  |   |
|---|---|
|  | Start Button<br>(to initiate Start command) |
|  | Load Button<br>(to activate Automatic Load) |
|  | Measurement View Button                     |
|  | Settings View Button                        |
|  | Alarms View Button                          |

The display now shows



After pressing the START button the machine will activate its horn and flasher light for 5 seconds, to notify that it will start.

| Active Buttons   |   |
|--|---|
|  | Stop Button<br>(to cancel Start command)    |
|  | Load Button<br>(to activate Automatic Load) |
|  | Measurement View Button                     |
|  | Settings View Button                        |
|  | Alarms View Button                          |



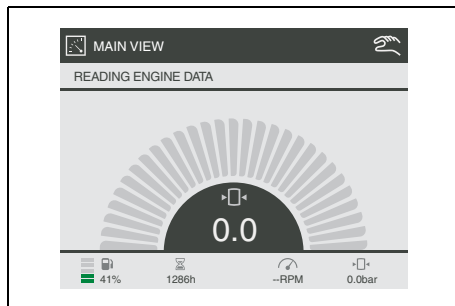

The display now shows

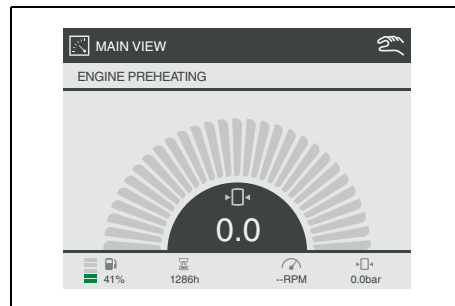

The engine electronics (ECU) will be powered up.

As soon as communication between compressor controller and engine controller is established, the machine will preheat according to the parameters of the engine controller.



| Active Buttons  |   |
|---|---|
|  | Stop Button<br>(to cancel Start command)    |
|  | Load Button<br>(to activate Automatic Load) |
|  | Measurement View Button                     |
|  | Settings View Button                        |
|  | Alarms View Button                          |

The engine starts cranking, the display shows

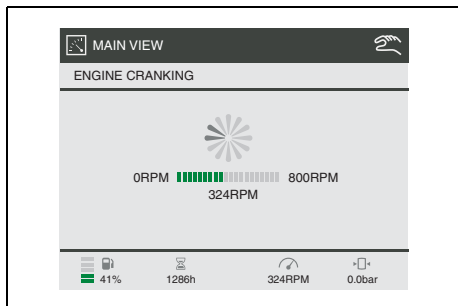

The engine cranks until 800 rpm is reached.

If 800 rpm is not reached within 30 seconds, the starting procedure is cancelled and the engine will rest for some time. (Resting time depends on cranking time).



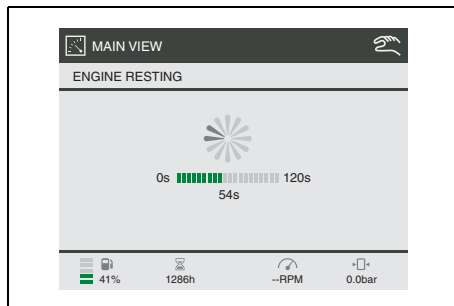

The display now shows

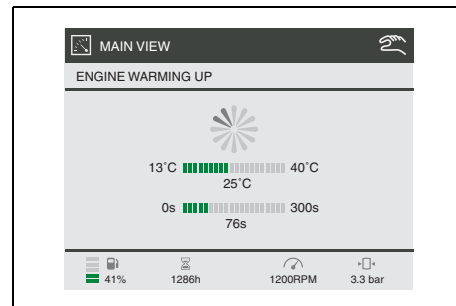

The engine starts running at idle speed. The display shows



The engine will run at minimum rpm, until the engine's coolant temperature reaches 40°C, with a minimum time of 15 seconds and a maximum time of 300 seconds.

| Active Buttons  |   |
|---|---|
|  | Stop Button<br>(to cancel Start command)    |
|  | Load Button<br>(to activate Automatic Load) |
|  | Measurement View Button                     |
|  | Settings View Button                        |
|  | Alarms View Button                          |

The display now shows

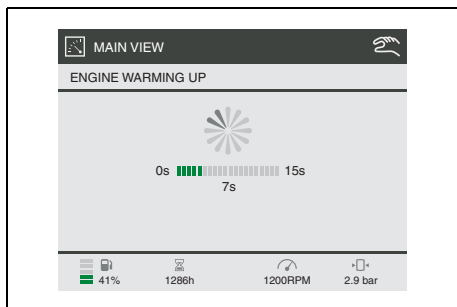

After warming up the machine is ready to be loaded and is waiting for a load command; the display shows

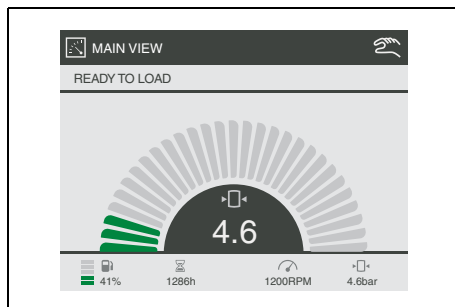

| Active Buttons |   |
|----------------|---|
|                | Stop Button<br>(to cancel Start command)    |
|                | Load Button<br>(to activate Automatic Load) |
|                | Measurement View Button                     |
|                | Settings View Button                        |
|                | Alarms View Button                          |





| Active Buttons |   |
|----------------|---|
|                | Stop Button<br>(to cancel Start command)    |
|                | Load Button<br>(to initiate Automatic Load) |
|                | Measurement View Button                     |
|                | Settings View Button                        |
|                | Alarms View Button                          |

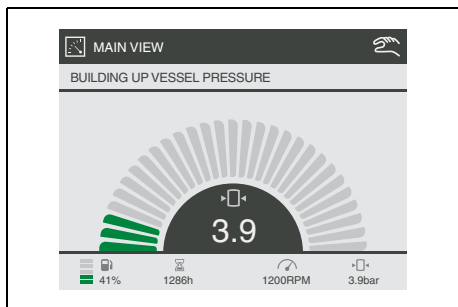

Press the load button, the display will show





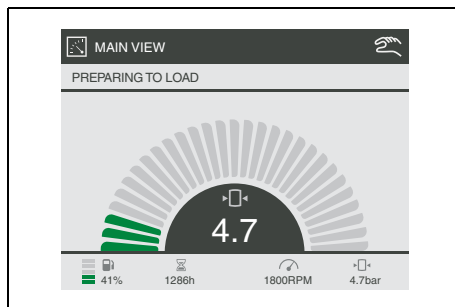

When the load button is pressed and the measured vessel pressure is lower than 4.5 bar, the controller will run a specific program to reach the requested 4.5 bar, in order to be able to load the machine. **(Only applicable for 2-stage machines).**

| Active Buttons   |  |
|--|--|
|  | Stop Button<br>(to cancel Start command) |
|  | Load Button<br>(to cancel Load command)  |
|  | Measurement View Button                  |
|  | Settings View Button                     |
|  | Alarms View Button                       |

The engine will now run at maximum rpm, the display will show





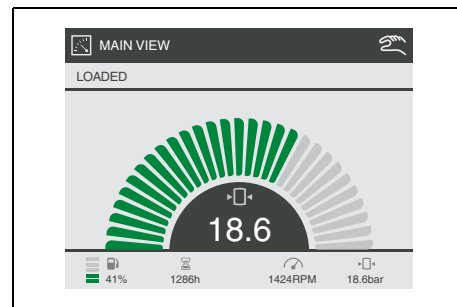

The loading valve will be energized and pressure starts building up.

| Active Buttons  |  |
|---|--|
|  | Stop Button<br>(to cancel Start command) |
|  | Load Button<br>(to cancel Load command)  |
|  | Measurement View Button                  |
|  | Settings View Button                     |
|  | Alarms View Button                       |

During loading the following display is shown (default display)



The controller controls the speed of the engine in order to meet the requested working pressure, at the most economical fuel usage.

| Active Buttons  |  |
|---|--|
|  | Stop Button<br>(to cancel Start command) |
|  | Load Button<br>(to cancel Load command)  |
|  | Measurement View Button                  |
|  | Settings View Button                     |
|  | Alarms View Button                       |

## During operation



The doors must be closed during operation and may be opened for short periods for inspection and adjustments only.



Be aware not to touch hot parts when the door is open.



When the engine is running, the air outlet valves (ball valves) must always be put in a fully opened or fully closed position.

## Regularly carry out following checks:

1. Ensure that the regulating valve (RV) is correctly adjusted, i.e. starts decreasing the engine speed when reaching the preset working pressure in the receiver.
2. Check the air outlet temperature of the compressor element.
3. Check the engine oil pressure, the coolant temperature and display of control box.
4. Avoid the engine running out of fuel. Nevertheless, if this happens, fill the fuel tank and prime the fuel system to speed up starting.

## Set the Pressure/Flow Setpoint

When the controller is in the Main View (shift between PRESSURE and FLOW VIEW with right/left arrows):

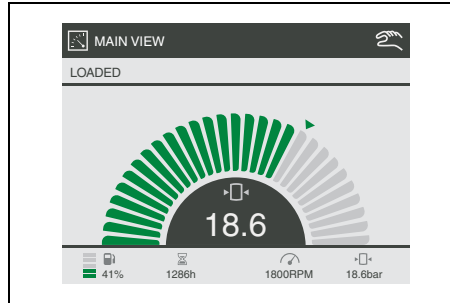

Press ENTER for 2 seconds, and the middle section becomes green (setting can be edited)

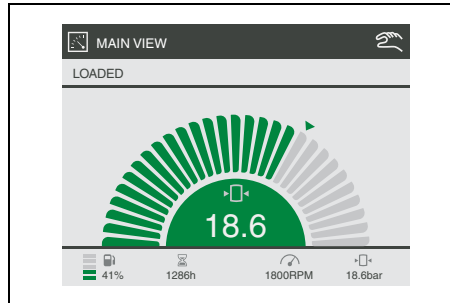

Press the UP/DOWN arrows to set the requested pressure/flow.

Press ENTER to confirm the new setting.

Some additional control features are available from Atlas Copco, such as dual pressure switch, remote start, auto start, remote pressure setting. If interested, please consult your Atlas Copco representative for more information.

## STOPPING

After pressing the STOP button the display will show:

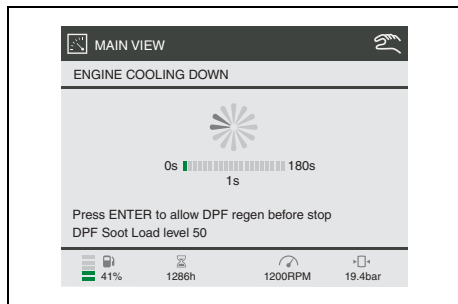

After a Stop command, or in case of a controlled stop alarm, the machine will cool down and run at minimum rpm for 3 minutes before it will stop.

If the Soot Load in the diesel particulate filter is above 30% when a stop command is given, the controller will ask the user if it is allowed to perform a complete DPF Regeneration cycle before stopping.

 **A full DPF Regeneration can take up to an hour.**





When ENTER is pressed the HEST icon will appear:

|  |           |
|--|-----------|
|  | HEST Icon |
|--|-----------|

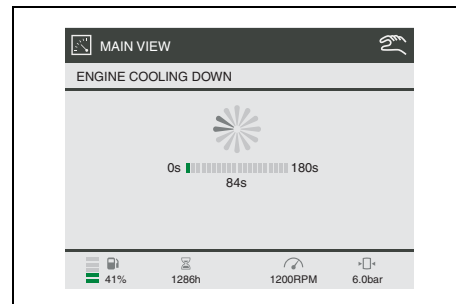
See paragraph **ALWAYS FIRST SHUT OFF THE CONTROLLER AND WAIT UNTIL THE DISPLAY IS DARK BEFORE SWITCHING THE BATTERY SWITCH TO POSITION "OFF".DIESEL PARTICULATE FILTER**

## REGENERATION.



| Active Buttons  |   |
|---|---|
|  | Start Button<br>(to initiate Start command) |
|  | Measurement View Button                     |
|  | Settings View Button                        |
|  | Alarms View Button                          |

After cooling down the engine will stop and the display will show

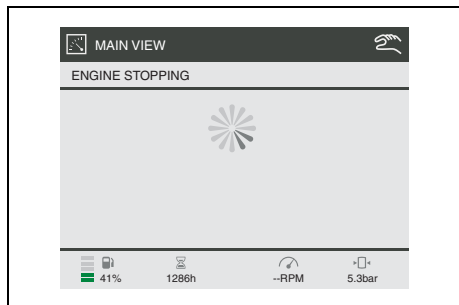

The engine is stopped, and the controller will do a double check to see if the engine is really stopped.

| Active Buttons |   |
|----------------|---|
|                | Start Button<br>(to initiate Start command) |
|                | Measurement View Button                     |
|                | Settings View Button                        |
|                | Alarms View Button                          |

## SHUTDOWN

When the machine is shutdown due to a critical alarm or an emergency stop the display will show

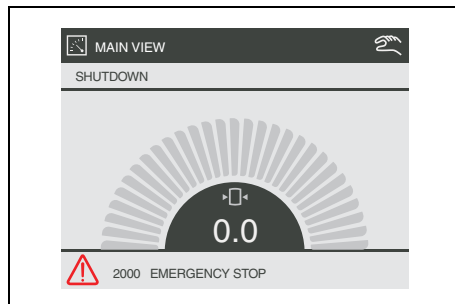

| Active Buttons |  |
|----------------|--|
|                | Measurement View Button                          |
|                | Settings View Button                             |
|                | Alarms View Button                               |
|                | Enter Button<br>(to acknowledge the shown alarm) |

## POWER OFF

Switch the controller off by switching the Power switch to the position “OFF”.

The compressor is equipped with a battery switch.

When the compressor is not in use, this switch must always be in the “OFF” position.

It is not allowed to use this switch as an emergency switch or for stopping the compressor.

It can damage the controller or the engine’s Electronic Control Unit when using the battery switch for stopping.

Always first shut off the controller and wait until the display is dark before switching the battery switch to position “OFF”. Diesel Particulate Filter Regeneration

## DIESEL PARTICULATE FILTER REGENERATION

When the Diesel Particle Filter regeneration process is kept at its default ‘AUTOMATIC’ setting, then the DPF regeneration will be performed automatically when the Soot Load exceeds 60%.

The controller display will indicate an ongoing DPF Regeneration by showing the HEST icon (High Exhaust System Temperature):

|  |           |
|--|-----------|
|  | HEST Icon |
|--|-----------|

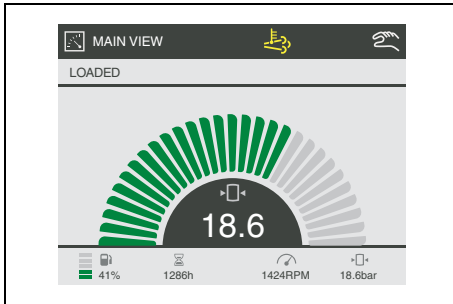

The DPF regeneration process will continue, until the Soot Load has become as low as possible, or until the engine is stopped.

When the DPF regeneration process is stopped, the HEST icon will disappear from the display.

## AUTOMATIC DPF REGENERATION (DEFAULT)

In specific cases, when the engine speed is constant at Minimum RPM, it can happen that the DPF regeneration already starts from 30% Soot Load (LSR - Low Speed Regeneration).

This can happen in following situations:

- Warming Up
- Not Loaded
- Loaded (when running in Unload condition - minimum RPM)
- Cooldown

When an LSR is ongoing while the soot load is less than 60%, and the engine speed changes (engine is stopped, machine gets loaded, ...), then the DPF Regeneration process will be stopped.

If the Soot Load is higher than 30% when cooling down should start (then an LSR is expected to be started) the controller will ask:

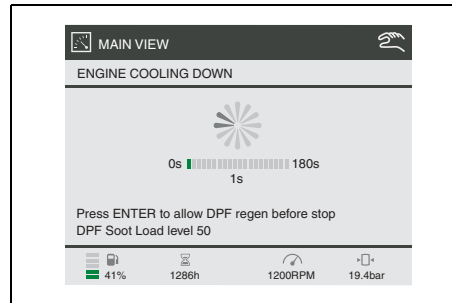

If Enter is pressed within 10 seconds then the controller will allow the DPF regeneration to be completed before the engine is stopped.

 **A full DPF Regeneration can take up to an hour.**

If Enter is not pressed (within 10 seconds), then the engine will be stopped after cooling down.

## INHIBIT DPF REGENERATION

When running in an environment where an elevated exhaust temperature is not allowed, it might be necessary to inhibit DPF regeneration. This has to be done at Service Level. The controller has now put the DPF Regeneration in a FORCED OFF mode, which is Inhibit DPF Regeneration.

The compressor controller will communicate with the engine controller and the (RED) Inhibit DPF regeneration icon will appear:

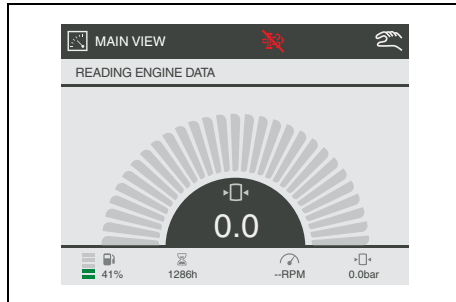
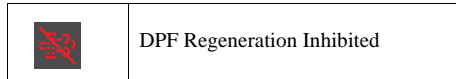

When the controller gets powered down, it will (at next power up) fall back to its default settings, meaning AUTOMATIC DPF regeneration.

## INCREASING SOOT LOAD

When the DPF Regeneration is Inhibited, or when the engine does not get sufficient possibility to automatically perform a full DPF Regeneration, the Soot Load will exceed the normal levels.

The controller will show the DPF Regeneration Needed Icon. In case of Inhibited DPF Regeneration, the DPF Regeneration Needed Icon will overwrite the DPF Inhibited Icon.

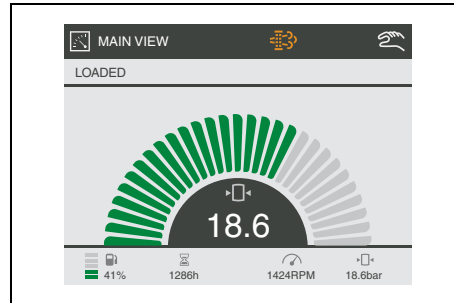
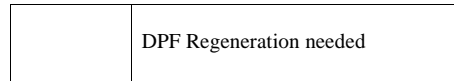

Required Action:

- Force DPF Regeneration, see paragraph **FORCE DPF REGENERATION**

When DPF Regeneration is started, the DPF Regeneration Needed icon will disappear and the HEST icon will pop-up.

## SOOT LOAD reaches 90% (only when DPF Regeneration is Inhibited)

When still no DPF regeneration is forced the next warning alarm will pop-up:

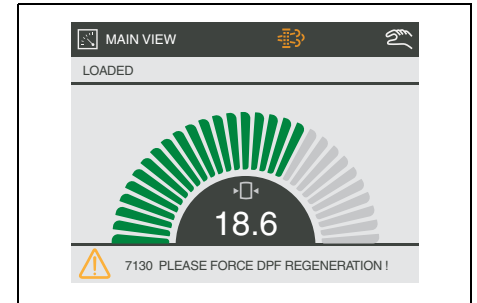
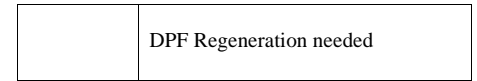

Required Action:

- Acknowledge the 'PLEASE FORCE DPF REGENERATION !' warning (press Enter while in the Main View).
- Force DPF Regeneration, see paragraph **FORCE DPF REGENERATION**

When DPF Regeneration is started, the DPF Regeneration Needed icon will disappear and the HEST icon will pop-up.

### SOOT LOAD reaches 92%

When still no DPF regeneration is forced the next warning alarm will pop-up.

Additionally the machine will be prevented to Load:

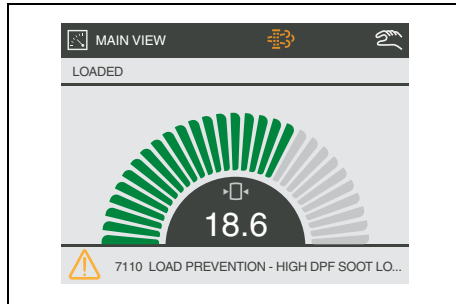
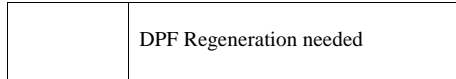

Required Action:

- Acknowledge the 'LOAD PREVENTION - HIGH DPF SOOT LOAD' inhibit load alarm (press Enter while in the Main View).
- Force DPF Regeneration, see paragraph **FORCE DPF REGENERATION**

When a DPF Regeneration is started, the DPF Regeneration Needed icon will disappear and the HEST icon will pop-up.

### SOOT LOAD reaches 98%

When no DPF regeneration is forced, the controller will force the machine into Not Loaded.

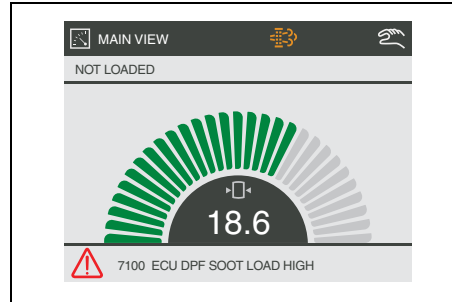
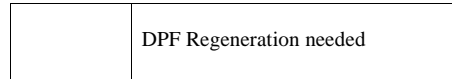

Required Action:

- Acknowledge the 'ECU DPF SOOT LOAD HIGH' warning (press Enter while in the Main View).
- Force DPF Regeneration, see paragraph **FORCE DPF REGENERATION**

When DPF Regeneration is started, the DPF Regeneration Needed icon will disappear and the HEST icon will pop-up.

### SOOT LOAD reaches 101%

If still no action is taken the following warning appears and the controller will perform a controlled shutdown.

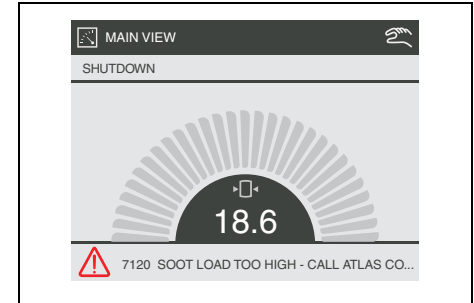

As soon as the engine is stopped, the DPF Regeneration Needed icon will disappear (engine electronics are powered down).



**Contact Atlas Copco for further actions to be taken.**

## **FORCE DPF REGENERATION**

### **If DPF Regeneration is Inhibited**

#### **Machine is not running:**

Power the controller down. At next power up, the DPF Regeneration settings will be back to default, and an Automatic DPF Regeneration will take place at the soonest appropriate moment.

#### **Machine is running:**

- Press the Settings View Button
- Enter the '1000 GENERAL SETTINGS' menu
- Scroll one line down and Enter the '1140 ECU DPF REGENERATION' menu

OR

- Scroll down and Enter the 'MODE' parameter
- Scroll down and Enter the 'AUTOMATIC' setting
- Press the Back button 3 times to get back to the Main View

DPF Regeneration setting will now be AUTOMATIC DPF REGENERATION.

Customer Level can now select between AUTO Regeneration & INHIBIT Regeneration, as long as the controller is not powered down (after power down, it will fall back to its default DPF Regeneration settings, and a Service Level is needed to go back to Inhibit DPF Regeneration).



## SETTINGS

For buttons to be used see “Control Panel”

### Acknowledge an Alarm

If an alarm becomes active, for example a Low Fuel Level Warning:

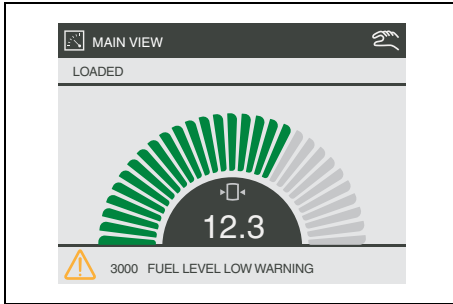

then this alarm can be acknowledged by pressing the ENTER button. If the fuel level is still low, the view will change to:

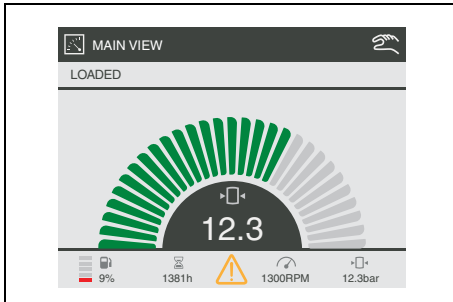

As soon as the fuel level is higher than the warning level, the alarm icon will automatically disappear.

As long as there is an alarm icon in the middle of the bottom part of the view, all active acknowledged / un-acknowledged alarms can be seen by pressing the ALARM VIEW button

Pressing the ALARM VIEW button again, will bring you back to the Main View.

### Set Clock

Press the SETTINGS VIEW button

- scroll to '1000 GENERAL SETTINGS'
- press ENTER
- scroll to '1290 DATE/TIME'
- ENTER the Date/Time menu
- scroll to the parameter you want to change
- ENTER this parameter.

To change the 'RTC Month', scroll to the preferred month and press ENTER.

To change any other RTC setting, the red figure is editable.

Scroll up/down and press ENTER to change. Use left/right to shift between editable figures.

Now press BACK until you're back in the Main View (or in the menu you require).

### Set Language

Press the SETTINGS VIEW button.

- scroll to '1000 GENERAL SETTINGS'
- press ENTER
- scroll to '1300 LANGUAGES'
- ENTER the LANGUAGES menu,
- ENTER the 'SETTINGS' parameter
- scroll to the preferred language
- press ENTER.

Now press BACK until you're back in the Main View (or in the menu you require).

### Set Units

Press the SETTINGS VIEW button,

- scroll to '1000 GENERAL SETTINGS'
- press ENTER
- scroll to the unit you would like to change:
  - '1340 TEMPERATURE UNITS'
  - '1350 PRESSURE UNITS'
  - '1360 FUEL FLOW UNITS'
  - '1370 AIR FLOW UNITS'
- ENTER the preferred menu
- ENTER the 'SETTINGS' parameter
- scroll to the preferred setting
- press ENTER.

Now press BACK until you're back in the Main View (or in the menu you require).

## **Change Display Settings**

Press the SETTINGS VIEW button

- scroll to '1000 GENERAL SETTINGS'
- press ENTER
- scroll to '1310 DISPLAY BACKLIGHT'
- ENTER the DISPLAY BACKLIGHT menu
- scroll to the setting you would like to change
- press ENTER.

To change a setting, the red figure is editable.

Scroll up/down and press ENTER to change. Use left/right to shift between editable figure.

Now press BACK until you're back in the Main View (or in the menu you require).

## **Go To Diagnostics**

Press the SETTINGS VIEW button

- scroll to '1000 GENERAL SETTINGS'
- press ENTER
- scroll to '1150 DIAGNOSTICS'
- ENTER the Diagnostics menu,
- ENTER the 'ENABLE' parameter
- scroll to 'ON' and press ENTER.

Now the ECU will get PAC (ignition) and one can perform ECU diagnostics (read DM1 List, DM2 List, ECU values, perform engine diagnostics, ...).

Now press BACK until you're back in the Main View (or in the menu you require).

To leave Diagnostics, press the STOP button.

## FAULT CODES

There are several parameters that are continuously watched.

When one of these parameters exceeds its specified limit the compressor will react depending the present status of the control box.

| Alarmcode | Alarmtext                             | Failclass           | Trigger |
|-----------|---------------------------------------|---------------------|---------|
| 1231      | FUEL FILL CHECK                       | Warning             | Xc      |
| 1503      | INITIAL OVERHAUL REQUIRED             | Warning             | Xc      |
| 1522      | MINOR OVERHAUL WITHIN ** H            | Warning             | Xc      |
| 1523      | MINOR OVERHAUL WITHIN ** D            | Warning             | Xc      |
| 1524      | MINOR OVERHAUL REQUIRED               | Warning             | Xc      |
| 1552      | MAJOR OVERHAUL WITHIN ** H            | Warning             | Xc      |
| 1553      | MAJOR OVERHAUL WITHIN ** D            | Warning             | Xc      |
| 1554      | LOAD PREVENTION - FIRE RISK           | Inhibit Load        | Xc      |
| 1558      | COMP. OIL CHANGE WITHIN ** H          | Warning             | Xc      |
| 1559      | COMP. OIL CHANGE WITHIN ** D          | Warning             | Xc      |
| 2000      | EMERGENCY STOP INPUT                  | Shutdown            | Xc      |
| 2040      | REMOTE EMERGENCY STOP                 | Shutdown            | Xc      |
| 2070      | COOLANT LEVEL LOW WARNING             | Warning             | Xc      |
| 2080      | COOLANT LEVEL LOW SHUTDOWN            | Shutdown            | Xc      |
| 2090      | ΔP AIRFILTERS HIGH                    | Warning             | Xc      |
| 2100      | NO PROJECTFILE DOWNLOADED             | Warning             | Xc      |
| 2752      | NAM OILTRONIX BYPASS CIRCUIT          | Shutdown After Stop | Xc      |
| 2762      | NAM OILTRONIX CLOSED CIRCUIT          | Shutdown After Stop | Xc      |
| 2772      | NAM AIRXPRT OPENED CIRCUIT            | Shutdown            | Xc      |
| 2782      | NAM AIRXPRT CLOSED CIRCUIT            | Shutdown            | Xc      |
| 3000      | FUEL LEVEL LOW WARNING                | Warning             | Xc      |
| 3010      | FUEL LEVEL LOW SHUTDOWN               | Controlled Stop     | Xc      |
| 3020      | FUEL LEVEL SENSOR CIRCUIT             | Warning             | Xc      |
| 3050      | VESSEL PRESSURE HIGH WARNING          | Controlled Stop     | Xc      |
| 3060      | VESSEL PRESSURE HIGH SHUTDOWN         | Shutdown            | Xc      |
| 3070      | VESSEL PRESSURE SENSOR CIRCUIT        | Shutdown            | Xc      |
| 3120      | REGULATING PRESSURE SENSOR CIRCUIT    | Shutdown            | Xc      |
| 3170      | AIR DISCHARGE PRESSURE SENSOR CIRCUIT | Warning             | Xc      |

| <b>Alarmcode</b> | <b>Alarmtext</b>                    | <b>Failclass</b>    | <b>Trigger</b> |
|------------------|-------------------------------------|---------------------|----------------|
| 3320             | INLET PRESSURE SENSOR CIRCUIT       | Shutdown            | Xc             |
| 3450             | BATTERY LOW ALARM                   | Indication          | Xc             |
| 3460             | BATTERY HIGH ALARM                  | Warning             | Xc             |
| 3660             | FIRE RISK - CHECK OILSTOPVALVE      | Shutdown            | Xc             |
| 3680             | OSV PRESSURE SENSOR CIRCUIT         | Controlled Stop     | Xc             |
| 3720             | INTERSTAGE PRESSURE SENSOR CIRCUIT  | Warning             | Xc             |
| 4000             | L.P. ELEMENT TEMPERATURE HIGH       | Warning             | Xc             |
| 4010             | L.P. ELEMENT TEMP. ALARM 2          | Controlled Stop     | Xc             |
| 4020             | L.P. ELEMENT TEMP. ALARM 3          | Shutdown            | Xc             |
| 4040             | L.P. ELEMENT TEMP. SENSOR CIRCUIT   | Shutdown            | Xc             |
| 4070             | AMBIENT TEMPERATURE SENSOR CIRCUIT  | Warning             | Xc             |
| 4100             | AIR DISCHARGE TEMPERATURE ALARM 1   | Warning             | Xc             |
| 4110             | AIR DISCHARGE TEMPERATURE ALARM 2   | Controlled Stop     | Xc             |
| 4120             | A.D. TEMPERATURE SENSOR CIRCUIT     | Warning             | Xc             |
| 4150             | H.P. ELEMENT TEMPERATURE ALARM 1    | Warning             | Xc             |
| 4160             | H.P. ELEMENT TEMPERATURE ALARM 2    | Controlled Stop     | Xc             |
| 4170             | H.P. ELEMENT TEMPERATURE ALARM 3    | Shutdown            | Xc             |
| 4190             | H.P. ELEMENT TEMP. SENSOR CIRCUIT   | Shutdown            | Xc             |
| 4220             | AFTERCOOLER AIR TEMP SENSOR CIRCUIT | Warning             | Xc             |
| 4230             | AFTERCOOLER FREEZING DANGER         | Indication          | Xc             |
| 5200             | AIR SHUT OFF                        | Shutdown            | Xc             |
| 6190             | CHARGE MONITORING FAIL              | Indication          | Xc             |
| 6327             | START FAILURE                       | Shutdown            | Xc             |
| 6329             | STARTER SPEED TOO LOW               | Shutdown            | Xc             |
| 6388             | VESSEL PRESSURE TOO LOW TO LOAD     | Indication          | Xc             |
| 6426             | UNINTENTIONAL RUN                   | Shutdown            | Xc             |
| 6427             | RUN FAILURE                         | Shutdown            | Xc             |
| 6428             | STOP FAILURE                        | Shutdown            | Xc             |
| 6708             | DRAINING 1                          | Warning             | Xc             |
| 6709             | DRAINING 2                          | Warning             | Xc             |
| 6749             | OILTRONIX FUNCTIONALITY DISABLED    | Warning             | Xc             |
| 6760             | OILTRONIX COUPLING FAILURE          | Shutdown After Stop | Xc             |
| 6769             | OILTRONIX COMPONENT FAILURE         | Shutdown            | Xc             |

| Alarmcode | Alarmtext                             | Failclass       | Trigger |
|-----------|---------------------------------------|-----------------|---------|
| 6981      | INLET VALVE POS. FAILURE              | Shutdown        | Xc      |
| 7002      | ECU COMMUNICATION                     | Shutdown        | Xc      |
| 7007      | ECU RED LAMP                          | Shutdown        | ECU     |
| 7008      | ECU AMBER LAMP                        | Warning         | ECU     |
| 7009      | ECU PROTECT LAMP                      | Warning         | ECU     |
| 7010      | ECU ENGINE SPEED TOO LOW              | Shutdown        | Xc      |
| 7020      | ECU ENGINE SPEED ALARM 2              | Shutdown        | Xc      |
| 7030      | ECU ENGINE COOLANT TEMP. ALARM        | Controlled Stop | Xc      |
| 7050      | ECU ENGINE AIR INLET TEMP. ALARM 1    | Controlled Stop | Xc      |
| 7100      | ECU DPF SOOT LOAD HIGH                | Warning         | Xc      |
| 7110      | PLEASE FORCE DPF REGENERATION !       | Inhibit Load    | Xc      |
| 7120      | LOAD PREVENTION - HIGH DPF SOOT LOAD  | Controlled Stop | Xc      |
| 7130      | SOOT LOAD TOO HIGH - CALL ATLAS COPCO | Warning         | Xc      |
| 7222      | COMBO COMMUNICATION FAILURE           | Warning         | Xc      |
| 7223      | COMBO PA SENSOR WARNING               | Warning         | Xc      |
| 7224      | COMBO RHA SENSOR WARNING              | Warning         | Xc      |
| 7225      | COMBO TA SENSOR WARNING               | Warning         | Xc      |

#### Details of ECU triggered alarms can be monitored via the ECU DM1 LIST menu

In case of ECU AMBER LAMP or ECU PROTECT LAMP:

Only possible when engine is running or if Diagnostics Mode is active.  
Access the ECU DM1 LIST menu via Alarm View.

In case of ECU RED LAMP:

Do NOT acknowledge the ECU RED LAMP alarm. DM1 alarms are automatically copied into the Alarm View, and can be read there.

For all ECU triggered alarms, the respective SPN code is shown in the ECU DM1 LIST

A full list of supported SPN codes is provided by the engine manufacturer.

For following alarms, the Xc controller also shows full text next to the SPN code:

ECU - FUEL FILTER PRESSURE  
ECU - INTERCOOLER TEMPERATURE  
ECU - FUEL PRESSURE  
ECU - FUEL FILTER PRESSURE  
ECU - WATER IN FUEL  
ECU - OIL LEVEL  
ECU - OIL FILTER PRESSURE  
ECU - OIL PRESSURE  
ECU - TURBO BOOST PRESSURE  
ECU - TURBO OIL PRESSURE  
ECU - INTAKE MANIFOLD TEMPERATURE  
ECU - AIR INLET PRESSURE  
ECU - COOLANT TEMPERATURE  
ECU - COOLANT LEVEL  
ECU - SUPPLY VOLTAGE

ECU - AMBIENT AIR TEMPERATURE  
ECU - AIR INLET TEMPERATURE  
ECU - FUEL TEMPERATURE  
ECU - OIL TEMPERATURE  
ECU - ENGINE SPEED  
ECU - INJECTOR 1  
ECU - INJECTOR 2  
ECU - INJECTOR 3  
ECU - INJECTOR 4  
ECU - INJECTOR 5  
ECU - INJECTOR 6  
ECU - INJECTOR 7  
ECU - INJECTOR 8  
ECU - SOOT LOAD

## EMERGENCY STOP

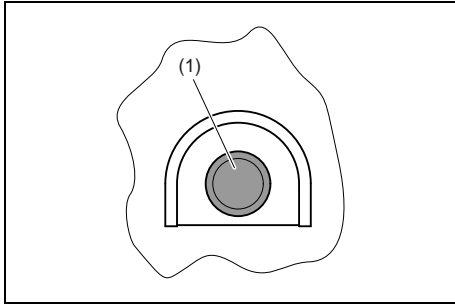

**The emergency stop button is only to be used in emergency situations; not for stopping procedures.**

When an emergency stop button (1) is pressed, power to all outputs is terminated, by the emergency stop itself (hardware) as well as by the software.

When the emergency stop button (1) is pressed the operator can unlock the emergency stop by turning it counterclockwise.

# Maintenance

## LIABILITY

The manufacturer does not accept any liability for any damage arising from the use of non-original parts and for modifications, additions or conversions made without the manufacturer's approval in writing.

## SERVICE PAKS

A Service Pak is a collection of parts to be used for a specific maintenance task, e.g. after 50, after 500 and after 1000 running hours.

It guarantees that all necessary parts are replaced at the same time keeping down time to a minimum.

The order number of the Service Paks are listed in the Atlas Copco Parts List (ASL).

### Use of service paks

Service Paks include all genuine parts needed for normal maintenance of both compressor and engine.

Service Paks minimize downtime and keep your maintenance budget low.

Order Service Paks at your local Atlas Copco dealer.

## SERVICE KITS

A service kit is a collection of parts to fit a specific repair or rebuilding task.

It guarantees that all necessary parts are replaced at the same time which improves the uptime of the unit.

The order numbers of the Service Kits are listed in the Atlas Copco Parts List (ASL).



**Contact Atlas Copco.**

## STORAGE

Run the compressor regularly, e.g. twice a week, until warm.

Load and unload the compressor a few times to operate the unloading and regulating components. Close the air outlet valves after stopping.



**If the compressor is going to be stored without running from time to time, protective measures must be taken.**

## SAFETY PRECAUTIONS



**Before performing any maintenance jobs always put the battery switch in the "OFF" position. See section Battery switch.**

**Always observe the applicable safety precautions. See section Safety during maintenance and repair.**

**Please note that when the battery switch is off there can still be some parts live!**

## PREVENTIVE MAINTENANCE SCHEDULE FOR THE COMPRESSOR

The schedule contains a summary of the maintenance instructions. Read the respective section before taking maintenance measures.

When servicing, replace all disengaged packings, e.g. gaskets, O-rings, washers.

For engine maintenance refer to Engine Operation Manual.

The maintenance schedule has to be seen as a guideline for compressors operating in a dusty environment typical to compressor applications. Maintenance schedule can be adapted depending on application, environment and quality of maintenance.

| Maintenance schedule                                       | Daily | 50 hours after initial start-up | Every 6 months or 500 hours | Yearly or every 1000 hours |
|--|-------|---------------------------------|-----------------------------|----------------------------|
| XRXS 567 Cd - XRXS 1240 CD7<br>XRXS 607 Cd - XRXS 1275 CD7 |       |                                 | 2912 6075 05                | 2912 6076 06               |
| XRVS 617 Cd - XRVS 1300 CD7<br>XRVS 647 Cd - XRVS 1350 CD7 |       |                                 | 2912 6075 05                | 2912 6075 06               |
| Engine oil level   | Check |                                 |                             |                            |
| Condensate (11)  | Drain |                                 |                             |                            |
| Compressor oil level                                       | Check |                                 |                             |                            |
| Coolant level  | Check |                                 |                             |                            |
| Air filter vacuator valves                                 | Empty |                                 |                             |                            |
| Fuel filter water drain                                    | Drain |                                 |                             |                            |
| ABS vessel drain   | Drain |                                 |                             |                            |
| Electrolyte level and terminals of battery                 |       | Check                           | Check                       | Check                      |
| Tyre pressure  |       | Check                           | Check                       | Check                      |
| Leaks in air-, oil- or fuel system (13)                    |       | Check                           | Check                       | Check                      |
| Oil cooler   |       |                                 | Clean                       | Clean                      |

*(to be continued on page 57)*



| <b>Maintenance schedule</b><br><i>(continuation of page 56)</i> | <b>Daily</b> | <b>50 hours after<br/>initial start-up</b> | <b>Every 6 months or<br/>500 hours</b> | <b>Yearly or every<br/>1000 hours</b> |
|---|--------------|--|--|---------------------------------------|
| Radiator  |              |  | Clean                                  | Clean                                 |
| Intercooler   |              |  | Clean                                  | Clean                                 |
| Torque of wheel nuts  |              | Check                                      | Check                                  | Check                                 |
| Brake system (if installed)                                     |              | Check/Adjust                               | Check/Adjust                           | Check/Adjust                          |
| Safety valve (10)   |              |  |  | Test                                  |
| Door hinges   |              |  | Grease                                 | Grease                                |
| Towing eye shaft or ball coupling and shaft                     |              |  | Grease                                 | Grease                                |
| Bleed-off valve unloader  |              |  |  | Replace                               |
| Oil stop valve  |              |  |  | Clean                                 |
| Rubber flexibles (13)   |              |  |  | Check                                 |
| Shut-down switches  |              |  |  | Check                                 |
| Pressure drop over oil separator element (2)                    |              |  |  | Replace/Measure                       |
| Fan V-belts (3)   |              | Adjust                                     | Adjust                                 | Adjust                                |
| Fuel tank   |              |  | Clean                                  | Clean                                 |
| Compressor oil (1) (8)  |              |  |  | Change                                |
| Compressor oil filter (6)                                       |              | Replace                                    |  | Replace                               |
| Coolant (9) (5)   |              |  |  | Analyse                               |
| Air filter element (1)  |              |  |  | Replace                               |
| Engine oil (3) (4)  |              |  | Change                                 | Change                                |
| Engine oil filter (3)   |              |  | Replace                                | Replace                               |
| Primary fuel filter (AC filter) (7)                             |              |  | Replace                                | Replace                               |
| Fuel prefilter (3) (7)  |              |  | Replace                                | Replace                               |
| Crankcase breather filter                                       |              |  | Clean                                  | Clean                                 |

*(to be continued on page 58)*

| <b>Maintenance schedule</b><br><i>(continuation of page 57)</i> | <b>Daily</b> | <b>50 hours after<br/>initial start-up</b> | <b>Every 6 months or<br/>500 hours</b> | <b>Yearly or every<br/>1000 hours</b> |
|---|--------------|--|--|---------------------------------------|
| Fuel filter (3) (7)   |              |  | Replace                                | Replace                               |
| Engine inlet and outlet valves (3) (12)                         |              |  | Adjust                                 | Adjust                                |
| Flow restrictor in oil scavenge line                            |              |  |  | Clean                                 |
| External fuel connection  | Check        |  |  |                                       |
| <b>Inspection by Atlas Copco Service Technician</b>             |              |  |  | Inspection                            |

## Notes



1. More frequently when operating in a dusty environment.
2. Replace the element when the pressure drop exceeds 0.8 bar (11.6 psi).
3. Refer to the engine operation manual.
4. 200 / 500 hours is only valid when using PAROIL 15W40.
5. Check coolant every year. Change coolant every 5 years.
6. Use Atlas Copco oil filters, with by-pass valve, as specified in the parts list.
7. Replace the fuel filters regularly. Gummed or clogged filters mean fuel starvation and reduced engine performance. The quality of the fuel determines the frequency of renewal.
8. See section **Oil specifications**.
9. The following part numbers can be ordered from Atlas Copco to check on inhibitors and freezing point:
  - 2913 0028 00 refractometer
  - 2913 0029 00 pH meter.
10. See section **Safety valve**.
11. See section **Before starting**.
12. The engine inlet and outlet valves initially need to be adjusted at 500 hours.
13. Replace all rubber flexibles each 6 years, according to DIN 20066.



**Keep the bolts of the housing, the lifting beam, tow bar and axles securely tightened. For torque values see section Technical specifications.**

## OIL SPECIFICATIONS



**It is strongly recommended to use Atlas Copco branded lubrication oils for both compressor and engine.**



**Only use synthetic compressor oil.**

High-quality, mineral, hydraulic or synthesized hydrocarbon oil with rust and oxidation inhibitors anti-foam and anti-wear properties is recommended.



**Never mix synthetic with mineral oil.**

**Remark:**

**When changing from mineral to synthetic oil (or the other way around), you will need to do an extra rinse:**

**After doing the complete change procedure to synthetic oil, run the unit for a few minutes to allow good and complete circulation of the synthetic oil.**

**Then drain the synthetic oil again and fill again with new synthetic oil. To set correct oil levels, proceed as in normal instruction.**

The viscosity grade should correspond to the ambient temperature and ISO 3448, as follows:

| Type of lubricant                      | Compressor | Engine       |
|--|------------|--------------|
| between -25°C (-13°F) and +30°C (86°F) | PAROIL S   | PAROIL 5W40  |
| between -10°C (14°F) and +30°C (86°F)  | PAROIL S   | PAROIL 15W40 |
| between -10°C (14°F) and +50°C (122°F) | PAROIL S68 | PAROIL 15W40 |

## COMPRESSOR OIL

### Synthetic compressor oil PAROIL S

|           | Liter | US gal | Imp gal | cu.ft | Order number |
|-----------|-------|--------|---------|-------|--------------|
| can       | 5     | 1.3    | 1.1     | 0.175 | 1615 5950 01 |
| can       | 20    | 5.3    | 4.4     | 0.7   | 1615 5951 01 |
| barrel    | 210   | 55.2   | 46      | 7.35  | 1615 5952 01 |
| container | 1000  | 265    | 220     | 35    | 1604 7422 00 |

### Synthetic compressor oil PAROIL S68

|        | Liter | US gal | Imp gal | cu.ft | Order number |
|--------|-------|--------|---------|-------|--------------|
| can    | 20    | 5.3    | 4.4     | 0.7   | 1604 7136 00 |
| barrel | 210   | 55.2   | 46      | 7.35  | 1604 7137 00 |

## ENGINE OIL

PAROIL from Atlas Copco is the ONLY oil tested and approved for use in all engines built into Atlas Copco compressors and generators.

Extensive laboratory and field endurance tests on Atlas Copco equipment have proven PAROIL to match all lubrication demands in varied conditions. It meets stringent quality control specifications to ensure your equipment will run smoothly and reliably.

The quality lubricant additives in PAROIL allow for extended oil change intervals without any loss in performance or longevity.

PAROIL provides wear protection under extreme conditions. Powerful oxidation resistance, high chemical stability and rust-inhibiting additives help reduce corrosion, even within engines left idle for extended periods.

PAROIL contains high quality anti-oxidants to control deposits, sludge and contaminants that tend to build up under very high temperatures. PAROIL's detergent additives keep sludge forming particles in a fine suspension instead of allowing them to clog your filter and accumulate in the valve/rocker cover area.

PAROIL releases excess heat efficiently, whilst maintaining excellent bore-polish protection to limit oil consumption.

PAROIL has an excellent Total Base Number (TBN) retention and more alkalinity to control acid formation.

PAROIL prevents Soot build-up

PAROIL is optimized for the latest low emission EURO -3 & -2, EPA TIER II & III engines running on low sulphur diesel for lower oil and fuel consumption.

PAROIL 5W40 is a Synthetic ultra high performance diesel engine oil with a high viscosity- index. Atlas Copco PAROIL 5W40 is designed to provide excellent lubrication from start-up in temperatures as low as -25°C (-13°F). PAROIL 15W40 is a mineral based high performance diesel engine oil with a high viscosity- index. Atlas Copco PAROIL 15W40 is designed to provide a high level of performance and protection in 'standard' ambient conditions as from -15°C (5°F).

### Synthetic engine oil PAROIL 5W40

|     | Liter | US gal | Imp gal | cu.ft | Order number |
|-----|-------|--------|---------|-------|--------------|
| can | 5     | 1.3    | 1.1     | 0.175 | 1604 6060 00 |
| can | 20    | 5.3    | 4.4     | 0.7   | 1604 6059 00 |

### Mineral engine oil PAROIL 15W40

|        | Liter | US gal | Imp gal | cu.ft | Order number |
|--------|-------|--------|---------|-------|--------------|
| can    | 5     | 1.3    | 1.1     | 0.175 | 1615 5953 00 |
| can    | 20    | 5.3    | 4.4     | 0.7   | 1615 5954 00 |
| barrel | 210   | 55.2   | 46      | 7.35  | 1615 5955 00 |

## OIL LEVEL CHECK

### CHECK ENGINE OIL LEVEL

Also consult the Engine Operation Manual for the oil specifications, viscosity recommendations and oil change intervals.

For intervals, see **Preventive maintenance schedule for the compressor.**

Check engine oil level according to the instructions in the Engine Operation Manual and if necessary top up with oil.

### CHECK COMPRESSOR OIL LEVEL

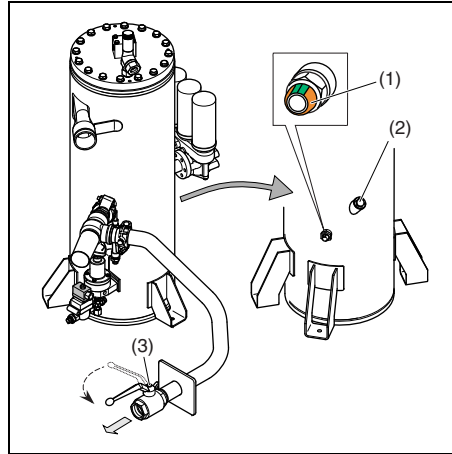

With the compressor standing horizontal, check the level of the compressor oil.

The pointer of the oil level gauge (1) must register in the upper extremity of the green range. Add oil if necessary.



**Before removing the oil filler plug (2), ensure that the pressure is released by opening an air outlet valve (3).**

## OIL AND OIL FILTER CHANGE

### ENGINE OIL AND OIL FILTER CHANGE

See section **Preventive maintenance schedule for the compressor.**

## TOPPING UP THE COMPRESSOR OIL

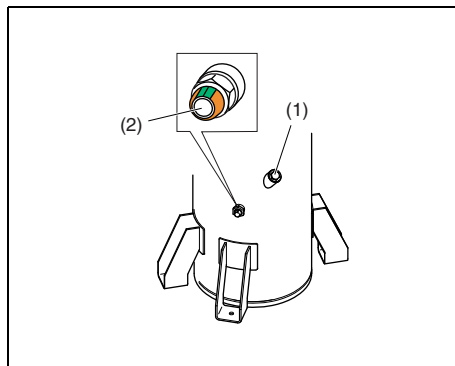

1. Stop the compressor. Wait a few minutes until the pressure is released through the automatic blow-down valve. Make sure that all pressure is released by loosening the filler plug (1) one turn.
2. Wait a few minutes until the oil level is constant.
3. Remove the filler plug (1) and top up with oil until the pointer of the oil level gauge (2) is in the upper part of the green area.
4. Reinstall and tighten the filler plug (1).

## COMPRESSOR OIL AND OIL FILTER CHANGE

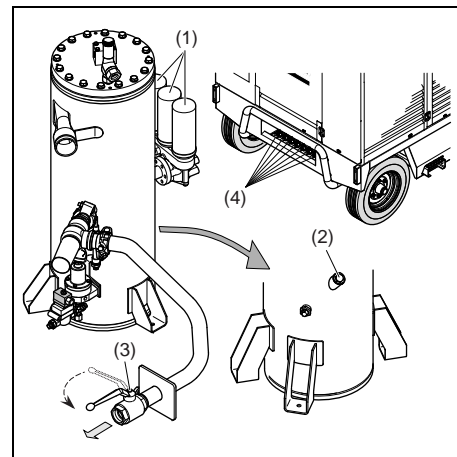

The quality and the temperature of the oil determine the oil change interval.

The prescribed interval is based on normal operating conditions and an oil temperature of up to 100 °C (212 °F) (see section **Preventive maintenance schedule for the compressor**).

When operating in high ambient temperatures, in very dusty or high humidity conditions, it is recommended to change the oil more frequently.



**In this case, contact Atlas Copco.**

## COOLANT SPECIFICATIONS

1. Run the compressor until warm. Close the outlet valve(s) (3) and stop the compressor. Wait until the pressure is released through the automatic blow-down valve. Unscrew the oil filler plug (2) one turn. This uncovers a vent hole, which permits any pressure in the system to escape.
2. Drain the compressor oil by removing all relevant drain plugs (4). Catch the oil in a drain pan. Screw out the filler plug (2) to speed up draining. After draining, place and tighten the drain plugs (4).
3. Remove the oil filters (1), e.g. by means of a special tool. Catch the oil in a drain pan.
4. Clean the filter seat on the manifold, taking care that no dirt drops into the system. Oil the gasket of the new filter element. Screw it into place until the gasket contacts its seat, then tighten one half turn only.
5. Fill the air receiver until the pointer of the oil level gauge is in the upper part of the green area. Be sure that no dirt gets into the system. Reinstall and tighten the filler plug.
6. Start the compressor and let it run unloaded for a few minutes.
7. Stop the compressor, wait a few minutes and top up with oil until the pointer of the oil level gauge is in the upper part of the green area.



**Never add more oil. Overfilling results in oil consumption.**



**Never remove the cooling system filler cap while coolant is hot.**

**The system may be under pressure. Remove the cap slowly and only when coolant is at ambient temperature. A sudden release of pressure from a heated cooling system can result in personal injury from the splash of hot coolant.**



**It is strongly recommended to use Atlas Copco branded coolant.**

The use of the correct coolant is important for good heat transfer and protection of liquid-cooled engines. Coolants used in these engines must be mixtures of good quality water (distilled or de-ionised), special coolant additives and if necessary freeze protection. Coolant that is not to manufacturer's specification will result in mechanical damage of the engine.

The freezing point of the coolant must be lower than the freezing point that can occur in the area. The difference must be at least 5 °C (9 °F). If the coolant freezes, it may crack the cylinder block, radiator or coolant pump.

Consult the engine's operation manual and follow the manufacturer's directions.



**Never mix different coolants and mix the coolant components outside the cooling system.**

## PARCOOL EG

**PARCOOL EG is the only coolant that has been tested and approved by all engine manufacturers currently in use in Atlas Copco compressors and generators.**

Atlas Copco's PARCOOL EG extended life coolant is the new range of organic coolants purpose designed to meet the needs of modern engines. PARCOOL EG can help prevent leaks caused by corrosion. PARCOOL EG is also fully compatible with all sealants and gasket types developed to join different materials used within an engine.

PARCOOL EG is a ready to use Ethylene Glycol based coolant, premixed in an optimum 50/50 dilution ratio, for antifreeze protection guaranteed to -40°C (-40°F).

Because PARCOOL EG inhibits corrosion, deposit formation is minimized. This effectively eliminates the problem of restricted flow through the engine coolant ducts and the radiator, minimizing the risk for engine overheating and possible failure.

It reduces water pump seal wear and has excellent stability when subjected to sustained high operating temperatures.

PARCOOL EG is free of nitride and amines to protect your health and the environment. Longer service life reduces the amount of coolant produced and needing disposal to minimise environmental impact.

## PARCOOL EG

|        | Liter | US gal | Imp gal | cu.ft | Order number |
|--------|-------|--------|---------|-------|--------------|
| can    | 5     | 1.3    | 1.1     | 0.175 | 1604 5308 00 |
| can    | 20    | 5.3    | 4.4     | 0.7   | 1604 5307 01 |
| barrel | 210   | 55.2   | 46      | 7.35  | 1604 5306 00 |

To ensure protection against corrosion, cavitation and formation of deposits, the concentration of the additives in the coolant must be kept between certain limits, as stated by the manufacturer's guidelines. Topping up the coolant with water only, changes the concentration and is therefore not allowed.

Liquid-cooled engines are factory-filled with this type of coolant mixture.

## PARCOOL EG Concentrate

|     | Liter | US gal | Imp gal | cu.ft | Order number |
|-----|-------|--------|---------|-------|--------------|
| can | 5     | 1.3    | 1.1     | 0.175 | 1604 8159 00 |



## HANDLING PARCOOL EG

PARCOOL EG should be stored at ambient temperatures, while periods of exposure to temperatures above 35 °C (95 °F) should be minimized. PARCOOL EG can be stored for a minimum of 5 years in unopened containers without any effect on the product quality of performance.

PARCOOL EG is compatible with most other coolants based on ethylene glycol, but you only get the benefits of 5 years protection when its used on its own. Exclusive use of PARCOOL EG is recommended for optimum corrosion protection and sludge control.

For simple density-measuring of Ethylene Glycol and Propylene Glycol in general the standard available 'density' measuring devices are used to measure the concentration of EG. In case a device is used to measure EG, no PG can be measured afterwards as a result of the difference in the density. More specific measurements can be done by the use of a refractometer. This device can measure both EG and PG. A mix of both products will be show unreliable results!

Mixed EG coolants with identical glycol type can be measured by use of a refractometer as well as the 'density' system. The mixed coolants will be considered as one product.

The use of distilled water is recommended. If you have exceptionally soft water it would be acceptable, as well. Basically, the engine metals are going to corrode to some extent no matter what water you use, and hard water will encourage the resulting metal salts to precipitate.

PARCOOL EG comes as a pre-mixed coolant to safeguard the quality of the complete product.

It is recommended that topping up of the cooling system is always done with PARCOOL EG.

## COOLANT CHECK



**Never remove the cooling system filler cap while coolant is hot.**

**The system may be under pressure. Remove the cap slowly and only when coolant is at ambient temperature. A sudden release of pressure from a heated cooling system can result in personal injury from the splash of hot coolant.**

In order to guarantee the lifetime and quality of the product, thus to optimise engine protection, regular coolant-condition-analysis is advisable.

The quality of the product can be determined by three parameters:

### Visual check

- Verify the outlook of the coolant regarding colour and make sure that no loose particles are floating around.

### pH measurement

- Check the pH value of the coolant using a pH-measuring device.
- The pH-meter can be ordered from Atlas Copco with part number 2913 0029 00.
- Typical value for EG = 8.6.
- If the pH-level is below 7 or above 9.5, the coolant should be replaced.

## Glycol concentration measurement

- To optimise the unique engine protection features of the PARCOOL EG the concentration of the Glycol in the water should be always above 33 vol.%.
- Mixtures with more than 68 vol.% mix ratio in water are not recommended, as this will lead to high engine operating temperatures.
- A refractometer can be ordered from Atlas Copco with part number 2913 0028 00.



**In case of a mix of different coolant products this type of measurement might provide incorrect values.**

## TOPPING UP/REPLACING COOLANT

- Verify if the engine cooling system is in a good condition (no leaks, clean,...).
- Check the condition of the coolant.
- If the condition of the coolant is outside the limits, the complete coolant should be replaced (see section **Replacing the coolant**).
- Always top-up with PARCOOL EG Concentrate / PARCOOL EG.
- Topping up the coolant with water only, changes the concentration of additives and is therefore not allowed.

## TOPPING UP WITHOUT DRAINING FROM THE COOLING SYSTEM

The quantity of PARCOOL EG Concentrate to be topped up can be estimated with the following formula and/or graph:

### Corrections concentrate in measured system towards 50% volume by using PARCOOL EG Concentrate

PN: 1604 8159 00

#### Example:

Total volume coolant =

14 Liter

Measured concentration =

33 Vol %

$$50 - \frac{33}{33} = 17 * \frac{14}{50} = 4,8 \text{ Liter PARCOOL EG Concentrate}$$

In case of expansion tank at low level, this quantity is to be filled without draining from the cooling system.

Top-up volume PARCOOL EG Concentrate without drainage

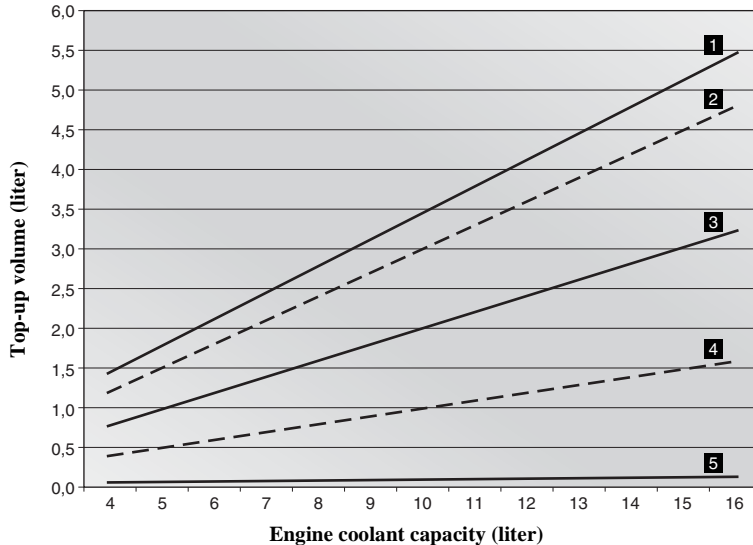

1. Refractometer indication -20° C (33%)
2. Refractometer indication -22° C
3. Refractometer indication -25° C
4. Refractometer indication -30° C
5. Refractometer indication -36° C

## TOPPING UP AFTER LIMITED QUANTITY DRAINING FROM THE COOLING SYSTEM

The quantity of PARCOOL EG Concentrate to be topped up after draining a calculated volume from the cooling system, can be estimated with the following formula and/or graph:

### Corrections concentrate in measured system towards 50% volume by using PARCOOL EG Concentrate

PN: 1604 8159 00

#### Example:

Total volume coolant =

80 Liter

Measured concentration =

33 Vol %

$$50 - \frac{33}{100} = 17 \quad \frac{17}{67} * 80 = 20 \quad \text{Liter PARCOOL EG Concentrate}$$

In case of expansion tank at normal level, this quantity is to be drained from the cooling system.

Top-up volume PARCOOL EG Concentrate without drainage

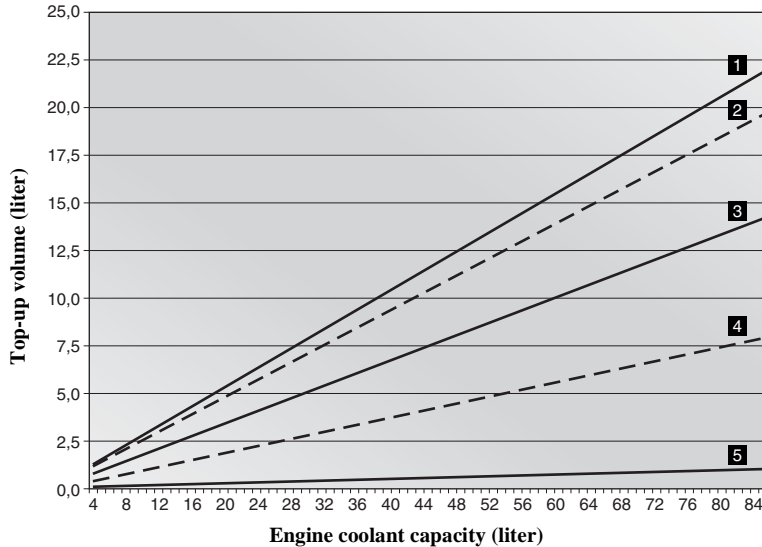

1. Refractometer indication -20° C (33%)
2. Refractometer indication -22° C
3. Refractometer indication -25° C
4. Refractometer indication -30° C
5. Refractometer indication -36° C

## REPLACING THE COOLANT

### Drain

- Completely drain the entire cooling system.
- Used coolant must be disposed or recycled in accordance with laws and local regulations.

### Flush

- Flush twice with clean water. Used coolant must be disposed or recycled in accordance with laws and local regulations.
- From the Atlas Copco Instruction book, determine the amount of PARCOOL EG required and pour into the radiator top tank.
- It should be clearly understood that the risk for contamination is reduced in case of proper cleaning.
- In case a certain content of 'other' coolant remains in the system, the coolant with the lowest properties influences the quality of the 'mixed' coolant.

### Fill

- To assure proper operation and the release of trapped air, run the engine until normal engine operation temperature is reached. Turn off the engine and allow to cool.
- Recheck coolant level and add if necessary.



**Caution: do not top off when the engine is hot.**

## CLEANING COOLERS

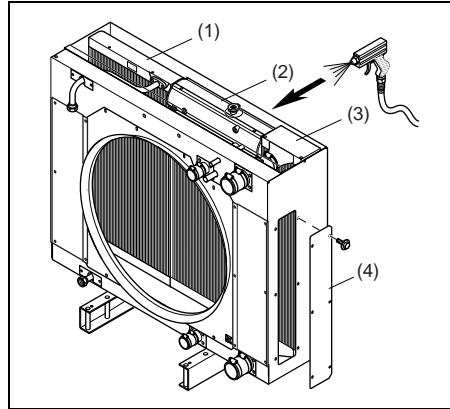

Keep the coolers (1), (2) and (3) clean to maintain the cooling efficiency.

Service doors (4) are provided on both sides of the fan cowl to allow easy access to the fan side surface of the coolers.



**Remove any dirt from the coolers with a fibre brush. Never use a wire brush or metal objects.**

Clean by air jet in the direction of the arrow.

Steam cleaning in combination with a cleansing agent may be applied (do not use jet at max. power).



**To avoid damaging the coolers, angle between jet and coolers should be approx. 90°.**

Close the service door(s).



**Protect the electrical and controlling equipment, air filters, etc. against penetration of moisture.**

**Never leave spilled liquids such as fuel, oil, coolant and cleansing agents in or around the compressor.**

## BATTERY CARE



**Before handling batteries, read the relevant safety precautions and act accordingly.**

If the battery is still dry, it must be activated as described in section **Activating a dry-charged battery**.

The battery must be in operation within 2 months from being activated; if not, it needs to be recharged first.

## ELECTROLYTE



**Read the safety instructions carefully.**

Electrolyte in batteries is a sulphuric acid solution in distilled water.

The solution must be made up before being introduced into the battery.



**Always pour the sulphuric acid carefully into the distilled water; never pour the water into the acid.**

## ACTIVATING A DRY-CHARGED BATTERY

- Take out the battery.
- Battery and electrolyte must be at equal temperature above 10 °C (50 °F).
- Remove cover and/or plug from each cell.
- Fill each cell with electrolyte until the level reaches the mark on the battery. If there is no mark on the battery, the level must be above the plates for at least 10 mm (0.4 in) to 15 mm (0.6 in).
- Rock the battery a few times so that possible air bubbles can escape; wait 10 minutes and check the level in each cell once more; if required, add electrolyte.
- Refit plugs and/or cover.
- Place the battery in the compressor.

## RECHARGING A BATTERY

Before and after charging a battery, always check the electrolyte level in each cell; if required, top up with distilled water only. When charging batteries, each cell must be open, i.e. plugs and/or cover removed.



**Use a commercial automatic battery charger according to its manufacturer's instructions.**

Apply with preference the slow charging method and adjust the charge current according to the following rule of thumb:

Battery capacity in Ah divided by 20 gives safe charging current in Amp.

## BATTERY MAINTENANCE

- Keep the battery clean and dry.
- Keep the electrolyte level above the plates or at the indicated level. Level above plates at least 10 mm (0.4 in) to 15 mm (0.6 in). Top up with distilled water only.
- Keep the terminals and clamps tight, clean, and lightly covered with petroleum jelly.

## COMPRESSOR ELEMENT OVERHAUL

When a compressor element is due for overhaul, it needs to be done by Atlas Copco. This guarantees the use of genuine parts and correct tools with care and precision.

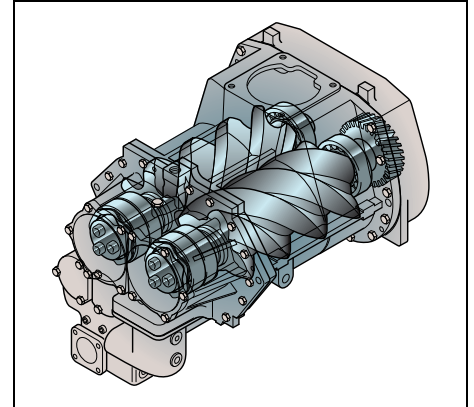

# Adjustments and servicing procedures

## ADJUSTMENT OF THE PNEUMATIC REGULATING SYSTEM

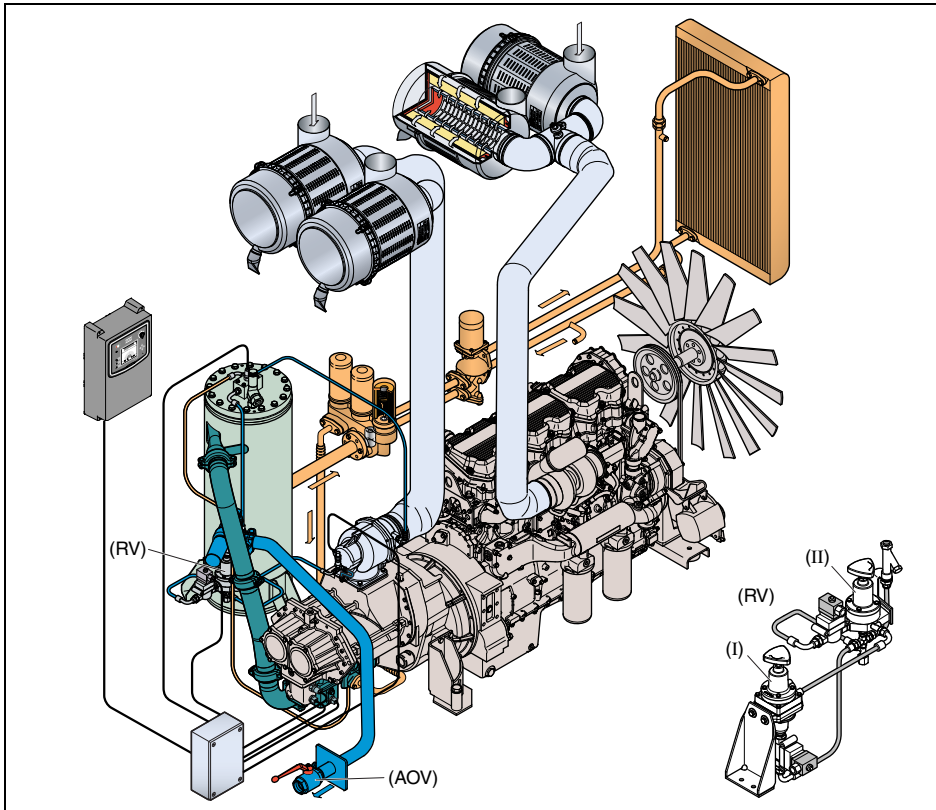

### Single pressure system

The working pressure is determined by the tension of the spring in the regulating valve (RV). This tension can be increased to raise the pressure and decreased to lower it by turning the adjusting wheel clockwise and anti-clockwise respectively.

To adjust the normal working pressure, proceed as follows:

1. Loosen the lock nut of the regulating valve.
2. Release Regulating Valve (turn out).
3. With the outlet valves (AOV) closed, adjust the regulating valve (RV), until a pressure is reached of nominal pressure + 2 bar (+ 29 psi).
4. Lock the regulating valve (RV) by fixing the lock nut.

### Dual pressure system (option for XRXS and XRYS)

The dual pressure system has two regulating valves marked with **I** and **II** and a switch at the rear for selecting the lower (**I**) or higher (**II**) working pressure.

Set the regulating valve (RV) marked with **I** at a working pressure lower than the regulating valve marked with **II**. This means the handle of RV **I** should be screwed in less than the handle of RV **II**. This pressure setting is very important. When done otherwise the system will not work correctly.

When RV **I** is set at a working pressure of maximum 25 bar (363 psi), the rpm will increase to 1900 rpm (instead of 1800 rpm) to deliver more FAD at this "lower" pressure. RV **I** can be set at a pressure higher than 25 bar (363 psi), but then there will be no speed increase.

## AIR FILTERS ENGINE / COMPRESSOR

### MAIN PARTS

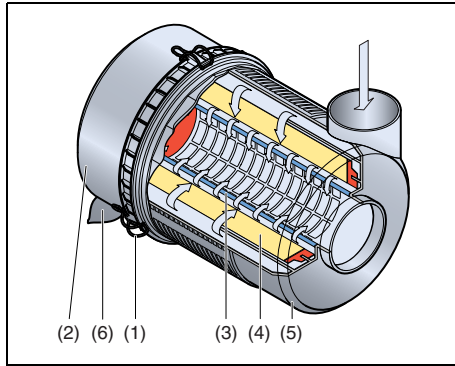

1. Snap clips (4x)
2. Dust trap cover
3. Safety cartridge
4. Filter element
5. Filter housing
6. Vacuator valve



**The Atlas Copco air filters are specially designed for the application. The use of non-genuine air filters may lead to severe damage of the engine and/or compressor elements.**

### CLEANING THE DUST TRAP

To remove dust from the dust trap pinch the vacuator valve (6) several times.

### REPLACING THE FILTER ELEMENT AND THE SAFETY CARTRIDGE

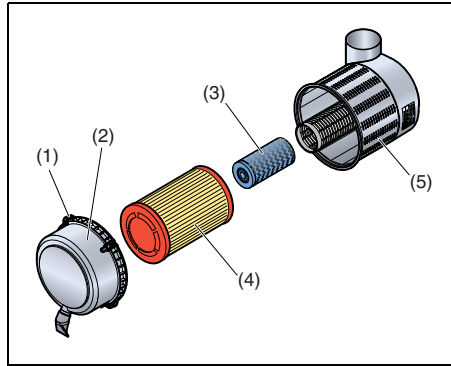

1. Release the snap clips (1) and remove the dust trap cover (2). Clean the inside of the cover.
2. Withdraw the filter element (4) and safety cartridge (3) from the housing (5).

Discard the filter element when damaged.

A dirty safety cartridge (3) is an indication of a malfunctioning filter element.



**Replace the filter element and the safety cartridge at the same time. New elements should be inspected for tears and punctures before installation.**



**The safety cartridge cannot be cleaned.**

3. Reassemble in reverse order of dismantling.
4. Inspect and tighten all air intake connections.

## AIR RECEIVER

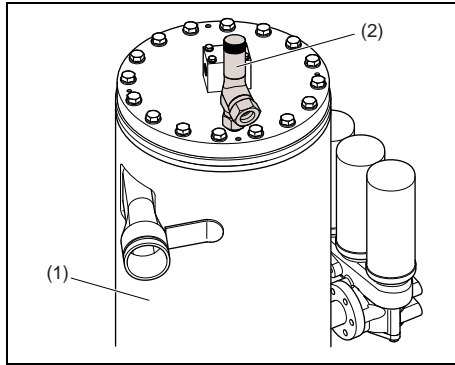

The air receiver (1) is tested according to official standards. Regularly have inspections carried out in conformity with local regulations.



**Daily drain condensate.**

## SAFETY VALVE



All adjustments or repairs are to be done by an authorized representative of the safety valve (2) supplier, see section Specific safety precautions.

Following checks must be carried out:

- A check of the opening of the lifting gear, twice a year.  
This can be done by screwing the cap of the valve anti-clockwise.
- A check of the set pressure once a year according to the local regulations. This check cannot be done on the compressor and must be carried out on a proper test bench.

## FUEL SYSTEM

### PRIMING INSTRUCTIONS



Fuel leaked or spilled onto hot surfaces or electrical components can cause a fire. To help prevent possible injury, turn the “ON/OFF” switch in position “OFF” when changing fuel filters or water separator elements. Clean up fuel spills immediately.

Prime the fuel system in order to fill the fuel filter. Prime the fuel system in order to purge trapped air (see paragraph **Overview icons**). The fuel system should be primed under the following conditions:

- Compressor is put in operation for the first time
- Running out of fuel
- Storage
- Replacement of the fuel filter



Do not loosen the fuel lines at the fuel manifold. The fittings may be damaged and/or a loss of priming pressure may occur when the fuel lines are loosened.



## REPLACING FILTER ELEMENTS

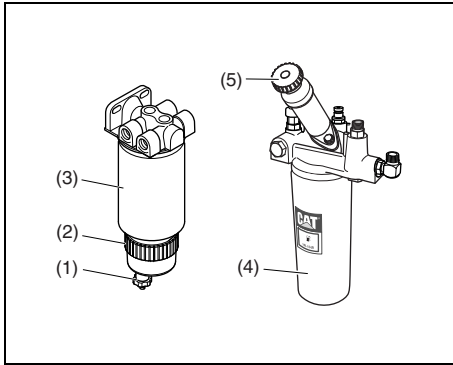

### Replacing the filter elements:

#### Installation instructions:

1. Drain fuel from the bowl.
2. Remove filter (2, 3), filterelement (4) and separate bowl (2) from element (3).
3. Apply film of gas oil to new bowl seat.
4. Screw bowl (2) to new element (3) tightly by hand.
5. Apply film of gas oil to new element seals.
6. Screw on filter (2, 3) and filterelement (4) tightly by hand.
7. Open head vent and operate pump (5). Close vent when fuel begins to purge.
8. Check for leaks, retighten if necessary.

#### Drain instructions:

1. Open bowl drain valve (1), operate pump (5) and pump water out.
2. Close drain valve (1).

## CLEANING CRANKCASE BREATHER FILTER

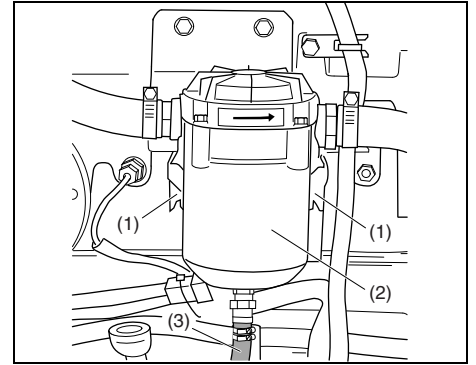

1. After switching off the engine, let it cool down for about 30 minutes.
2. Open the clasps (2) and carefully separate the bowl from the head. Be aware that hose (3) is still attached.
3. Take out the wire mesh and clean it in a solvent (diesel fuel).
4. Thoroughly dry the wire mesh with compressed air.
5. Put the wire mesh in the bowl and mount the bowl to the head. Do not twist hose (3).

## MAINTENANCE QUICK ACTION FUEL COUPLINGS

Even with proper selection and installation, quick action coupling life may be significantly reduced without a continuing maintenance program. Frequency should be determined by the severity of the application and risk potential. A maintenance program must be established and followed by the user and must include the following as a minimum:

### Visual inspection of quick action couplings:

Any of the following conditions require immediate shut down and replacement of the quick action coupling:

- Cracked, damaged, or corroded quick action coupling parts.
- Leaks at the fitting, valve or mating seal.
- Broken coupling mounting hardware, especially breakaway clamps.

### Visual inspection all other:

- Leaking seals or port connections.
- Excess dirt build-up on the coupling locking means or on the interface area of either coupling half.
- Defective clamps, guards, and shields.
- Fuel level system and any entrapment.

### Functional test:

Operate the system at maximum operating pressure and check for possible malfunctions and freedom from leaks. Personnel must avoid potential hazardous areas while testing and using the system.

### Replacement intervals:

Specific replacement intervals must be considered based on previous service life, government or industry recommendations, or when failures could result in unacceptable downtime, damage or injury risk.

## BRAKE ADJUSTMENTS

### BRAKE SHOE ADJUSTMENT WAGON

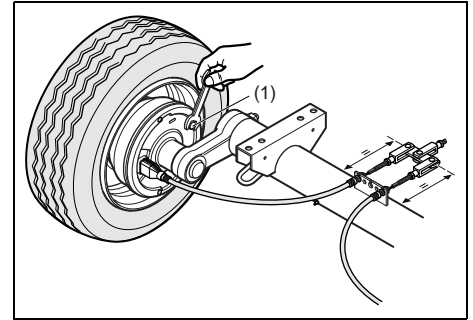

- Tighten the adjustment nut (1) on the wheel brake with a spanner until the wheel will not rotate in the direction of travel.
- Centre the brake shoes by applying the parking brake several times.
- Turn back the adjustment bolt (1) by approximately one turn, until no braking effect can be felt when the wheel is turned in a forward direction.
- Check the position of the brake equalizer compensators with the parking brake applied.
- Positioned at right angles to the brake rods = even play on both wheel brakes.
- Re-adjust brakes if necessary.
- As a check, apply the parking brake slightly and check that the braking effect on the wheels (in the direction of travel) is the same on the right and on the left.

## BRAKE ADJUSTMENT WAGON

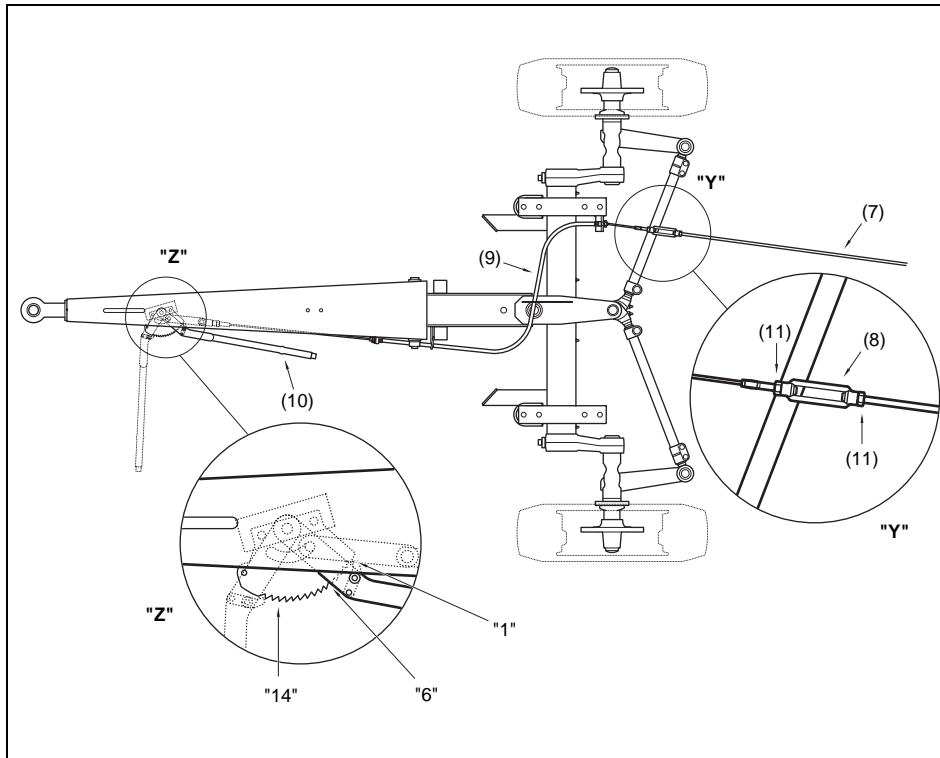

### Adjusting the linkage

- The parking brake is adjusted by using the turnbuckle (8). Adjust till the play in the linkage is 1-3 mm (max. 3mm is allowed).
- Apply the parking brake lever several times by hand with a force of 200 to 300 N and put it back into the -not engaged- tooth "1" position. Adjust the turnbuckle (8) as described above.



**Tighten all lock nuts (11)**  
(Torque: 24 Nm).

### Testing the parking brake

- For testing the parking brake, apply the parking brake lever. Brake power must be reached between the 6th and 14th tooth of the toothed segment ("Z").

# Problem solving

It is assumed that the engine is in good condition and that there is adequate fuel flow to the filter and injection equipment.



**An electrical fault must be traced by an electrician.**

Make sure that the wires are not damaged and that they are clamped tight to their terminals.

For denomination of switches, relays, etc., see **Electric system**.

See also section **Control panel**.

## Problem: Compressor capacity or pressure below normal.

| Possible faults                                     | Corrective actions   |
|---|--|
| Air consumption exceeds capacity of compressor.     | Check equipment connected.   |
| Choked air filter elements (AF).                    | Remove and inspect elements. Clean or replace, if necessary.   |
| Regulating valve (RV) defective.                    | Have regulating valve removed and inspected by an Atlas Copco Service representative.  |
| Blow down valve stuck in open position.             | Check and correct as necessary.  |
| Loading valve (LV) leaking past O-ring.             | With compressor running at max. load speed, disconnect hose leading to unloader. If air leaks from the hose, remove and inspect loading valve. Replace damaged or worn O-rings.  |
| Oil separator element clogged.                      | Have element removed and inspected by an Atlas Copco Service representative.   |
| Air intake throttle valve remains partially closed. | Remove air filters, air intake manifold and throttle valve spring seat. Withdraw the valve and inspect. Replace parts where necessary. Caution: the spring seat is fixed with 4 short and 2 long setscrews: first remove the short screws, then release the spring tension unscrewing the long ones. |
| Safety valve (SV) leaking.                          | Remove and inspect. Replace if not airtight after reinstallation.  |
| Blow-off valve leaking.                             | Remove and inspect. Replace if necessary.  |

**Problem: Pressure in air receiver rises above maximum and causes safety valve to blow.**

| Possible faults  | Corrective actions   |
|--|--|
| Regulating valve (RV) opens too late or its ball valve spring is broken. | Have regulating valve removed and inspected by an Atlas Copco Service representative.  |
| Air leaks in regulating system.  | Check hoses and their fittings. Stop leaks; replace leaking hoses.   |
| Air intake throttle valve does not close for some reason.                | Remove air filters, air intake manifold and throttle valve spring seat. Withdraw the valve and inspect. Replace parts where necessary. Caution: the spring seat is fixed with 4 short and 2 long setscrews: first remove the short screws, then release the spring tension unscrewing the long ones. |
| Minimum pressure valve malfunctioning.                                   | Remove and inspect valve.  |
| Blow-off valve malfunctioning.   | Remove and inspect valve.  |

**Problem: After working some time, the unit stops through a shutdown switch.**

| Possible faults                       | Corrective actions                               |
|---------------------------------------|--|
| Engine oil pressure too low.          | Refer to the engine instruction manual.          |
| Compressor or engine overheating.     | See corrective actions "Compressor overheating". |
| Fuel tank contains insufficient fuel. | Fill fuel tank.                                  |
| Low coolant level.                    | Top up cooling system.                           |

**Problem: Air and oil mist expelles from air filters immediately after stopping.**

| Possible faults                   | Corrective actions   |
|-----------------------------------|--|
| Check valve at element outlet.    | Remove and inspect. Replace if necessary. Replace air filter elements and safety cartridges. Check the oil level and add oil if necessary. Run the compressor for a few minutes, stop and recheck oil level. |
| Plunger of oil stop valve jammed. | Remove and inspect. Replace if necessary. Replace air filter elements and safety cartridges. Check the oil level and add oil if necessary. Run the compressor for a few minutes, stop and recheck oil level. |

## Problem: Compressor overheating.

| Possible faults  | Corrective actions   |
|--|--|
| Insufficient compressor cooling.                             | Locate compressor away from walls; when banked with other compressors, leave space between them. |
| Oil cooler clogged externally.                               | Clean oil cooler. Refer to section <b>Cleaning coolers</b> .                                     |
| Oil cooler clogged internally.                               | Consult Atlas Copco.   |
| Oil filters clogged.   | Replace oil filters.   |
| Oil level too low.   | Check oil level. Top up with recommended oil if necessary.                                       |
| Thermostatic by-pass valve remains stuck in opened position. | Remove valve and check for proper opening and closing. Replace if out of order.                  |
| Fan blade(s) broken.   | Check and correct if necessary.  |
| Oil stop valve malfunctioning.                               | Remove and inspect valve.  |
| Oil separator element (OS) clogged.                          | Have element removed and inspected by an Atlas Copco Service representative.                     |

## Alternator precautions

1. Never reverse the polarity of the battery or the alternator.
2. Never break any alternator or battery connections while the engine is running.
3. When recharging the battery, disconnect it from the alternator. Before using booster cables to start the engine, be sure of the polarity and connect the batteries correctly.
4. Never operate the engine without the main or voltage sensing cables connected in the circuit.

## HEATER FAILURE

**Problem: Heater does not start when switched on.**

| Possible faults                       | Corrective actions                              |
|---------------------------------------|---|
| No fuel.                              | Check fuel level.                               |
| Fuse blown.                           | Check fuse.                                     |
| Bad electrical contact.               | Check electrical wiring.                        |
| Blocked air duct or exhaust gas duct. | Check combustion air duct and exhaust gas duct. |
| Glow plug defective.                  | Replace glow plug.                              |
| Fan motor defective.                  | Replace fan motor.                              |

**Problem: Flame extinguishes.**

| Possible faults | Corrective actions         |
|-----------------|----------------------------|
| Overheating     | Cool down and start again. |

**Problem: Heater shuts off.**

| Possible faults                          | Corrective actions |
|--|--------------------|
| Upper or lower voltage limit is reached. | Check power.       |

**Problem: Control unit locked.**

| Possible faults                                  | Corrective actions  |
|--|---------------------|
| Device switched off and on again too many times. | Contact your agent. |

## OILTRONIX FAILURE

**Manually locking the valve (temporary solution)**



Disconnect the connector (1) of the stepper motor, to ensure that the stepper motor does not try to rotate the valve.

Rotate the white coupling of the valve manually until the blind hole (2) in the coupling is in line with the threaded hole (3) in the housing.



**Check the correct position of the blind hole with a  $\varnothing$  4 mm pin.**

Block the valve by screwing a bolt (M5 x 20) through the housing and in the blind hole in the coupling.



**Contact Atlas Copco for a thorough scan and repair.**

# Available options

## UNDERCARRIAGE

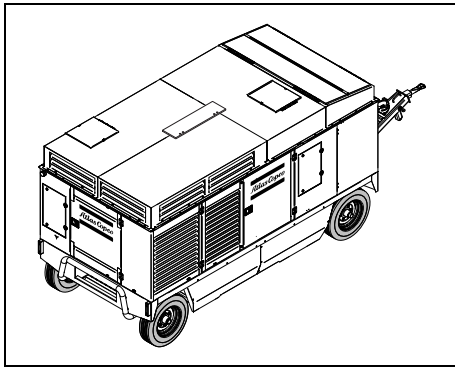

The undercarriage makes it possible to move the compressor on the site with a truck to the location where it is needed. This option exits of rubber damped axles, four wheels and a tow bar. The wheels are also equipped with brakes operated from the brake handle on the tow bar.

## SUPPORT MOUNTED / LARGE FUELTANKS

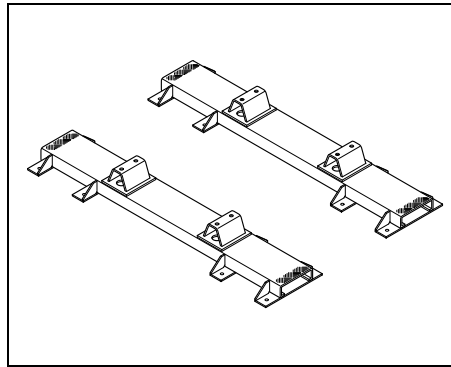

With the option “Support mounted” it is possible to fix the compressor to a truck for more flexibility or to a frame when it is to be used permanently in an installation.

In combination with the support mounted it is also possible to integrate larger fuel tank to get larger intervals between two fuel supply actions.

## SKID / LARGE FUELTANKS

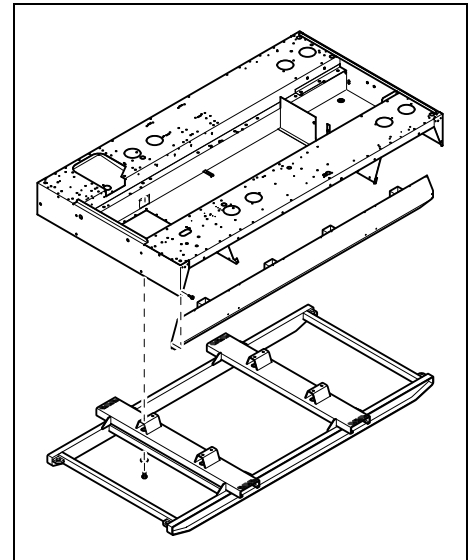

The skid is ideal in circumstances where the site is impossible to reach by truck. It allows transportation by crane or fork lift truck. When on the ground it can be pushed into the exact location.

In combination with the skid it is also possible to integrate larger fuel tank to get larger intervals between two fuel supply actions.



## WHEEL CHOCKS

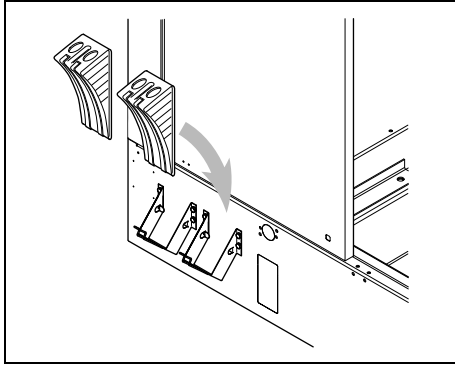

For extra safe parking on slopes.

## ADDITIONAL FUELFILTER

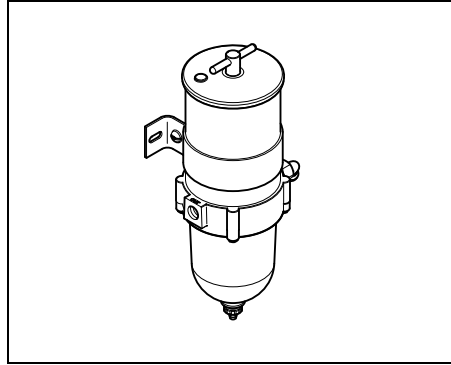

In dusty environments or in situations where the fuel quality is not up to the normal standard, this additional fuel filter gives an extra protection to the fuel/combustion system.

## ELECTRIC REFUEL PUMP

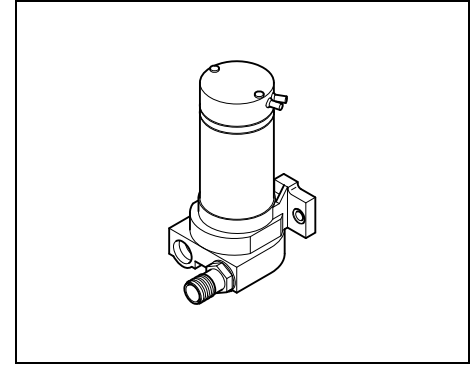

The electric refuel pump makes it easy to refuel the compressor on site when refuelling from tanks or containers. This option also contains a suction hose with strainer.

When switched on the electric refuel pump will be automatically switched off when:

- the tank is full,
- the tank from which is being refilled is empty.

## EXTERNAL FUEL CONNECTION

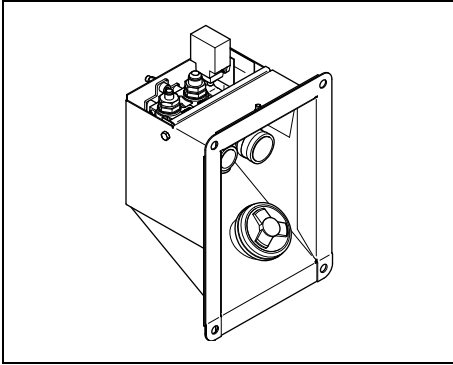

When a compressor is operated on site for a longer period it is advisable to supply the fuel through external fuel connections. When using this option the regular refuelling by tanker it is no more needed. Consequently there is also less risk for contamination when refuelling.

## SPARK ARRESTOR

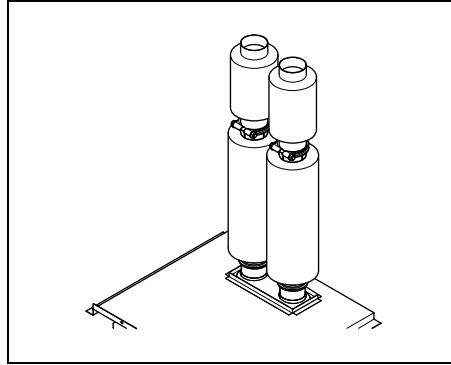

The certified spark arrester is an addition to the exhaust that makes it possible to operate the compressor in hazardous environments like refineries where there is a possibility that inflammable fumes can be released. The spark arrester prevents any hot (burning) particles from getting into the open air.

## PREHEATER

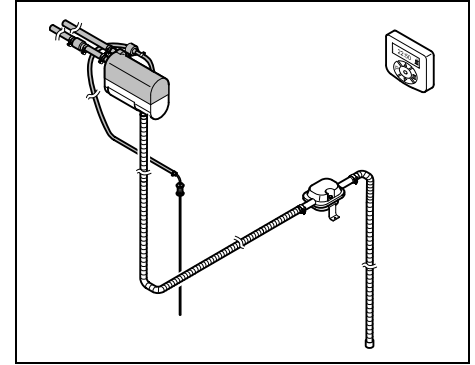

The preheater is a device for preheating the cooling fluid before starting when operating at low temperatures. The engine will start more easy. Additionally the preheater will lengthen the life span of the engine as there are no cold starts.

## COLD WEATHER PACKAGE

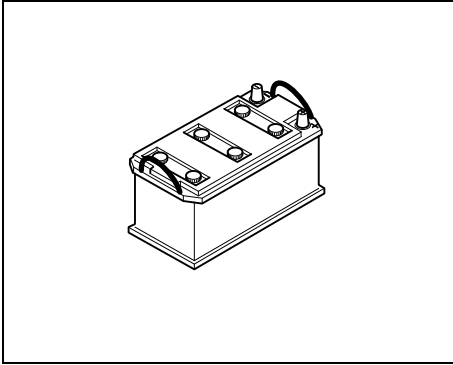

The cold start option consists of larger batteries and a blow off valve to be able to start the engine at temperatures between  $-10^{\circ}\text{C}$  ( $14^{\circ}\text{F}$ ) and  $-25^{\circ}\text{C}$  ( $-13^{\circ}\text{F}$ ). It also includes a preheater.

## INLET SHUTDOWN VALVE

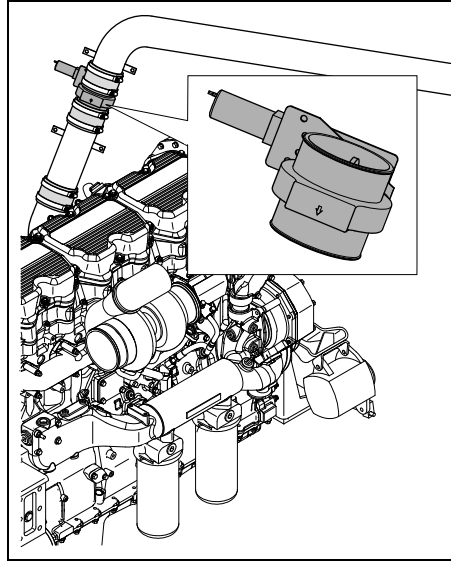

The inlet shut down valve is a safety device preventing the engine from over speeding when sucking in combustible fumes. When the engine max. RPM is exceeded a pneumatically controlled solenoid valve closes off the air inlet and the fuel supply to the engine is cut.

## OILTRONIX

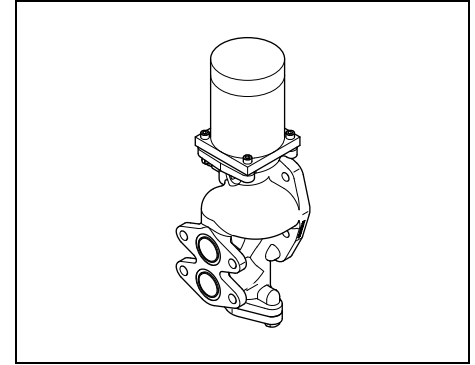

The OILTRONIX is an Electronic Oil Management System for compressors providing an optimal oil injection temperature that reduces the condensation of water in the oil. This will result in a longer life of components in the compressor system.

Because of the OILTRONIX the unit will also be operating at temperatures kept as low as possible.

The OILTRONIX is standard on the XRXS and XRYS types and option on the XRVS types.

**REGULATING SYSTEM SINGLE PRESSURE  
FUEL EXPERT**

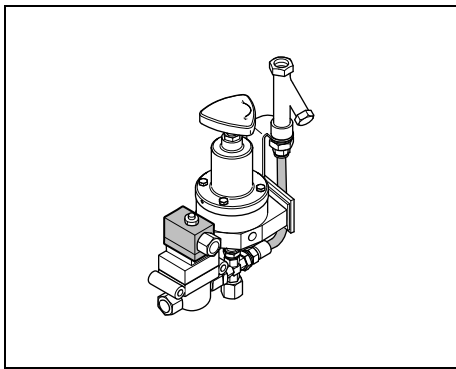

This is a control module that regulates engine speed and the air inlet to optimise fuel consumption depending on the working conditions, and the output required.

This option contains one regulating valve.

**REGULATING SYSTEM DUAL PRESSURE  
NO FUEL EXPERT**

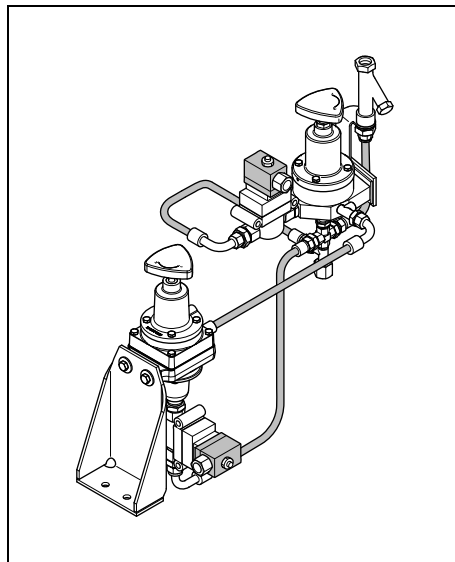

With this option it is possible to set the pressure to two particular pressures.

**REGULATING SYSTEM DUAL PRESSURE  
FUEL EXPERT**

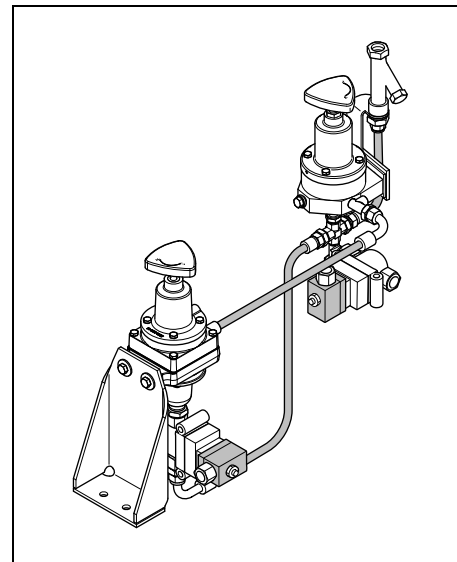

This option combines the dual pressure regulating system with the fuel optimising system, thus saving on fuel costs.

## PRESSURE REGULATOR EC

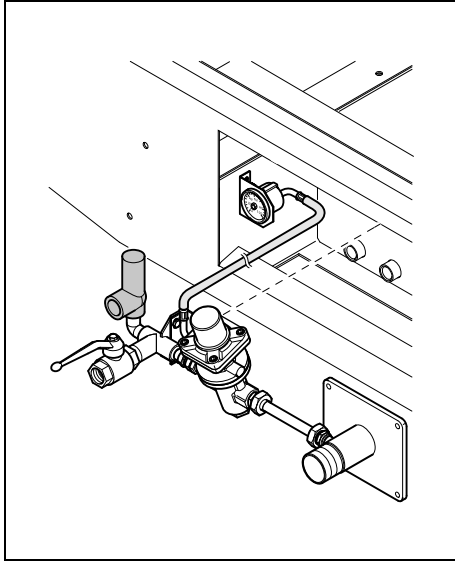

A pressure regulating system according to European standards for reducing the operating pressure. It will limit the operating pressure to 7 bar and allow the operation of hand held pneumatic tools.

## PRESSURE REGULATOR ASME

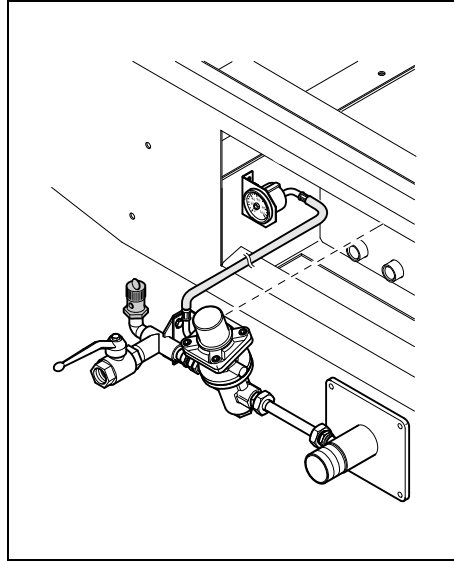

A pressure regulating system according to US standards for reducing the operating pressure. It will limit the operating pressure to 7 bar and allow the operation of hand held pneumatic tools.

## FORK LIFT SLOTS

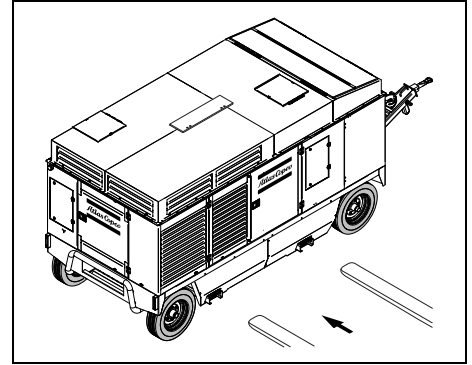

With fork lift slots the compressor can easily be moved with a fork lift truck on building sites where it is impossible to use a towing truck.

## AFTER-COOLER

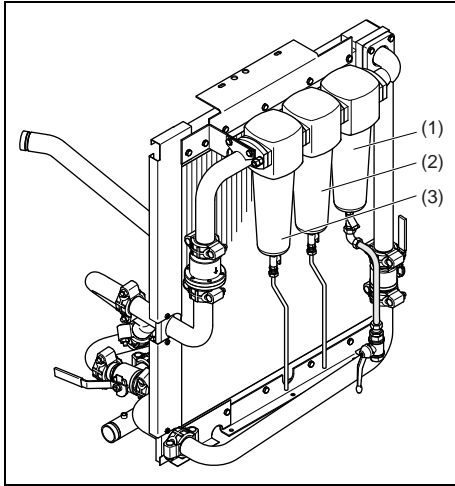

An integral after-cooler, with water separator (1), is available to reduce the outlet air temperature to ambient plus 10°C (18°F) and cut water content to a mere 15%. The installation includes a by-pass over the after-cooler.

For applications that demand quality air, a fine filtration unit (2) can be specified with the after-cooler package. This will remove oil and particles down to 0.01 mg/m<sup>3</sup>.

For purer, but not breathing, air, an active charcoal filtration unit (3) can be specified with the after-cooler package. This removes oil and oil vapour content to 0.003 mg/m<sup>3</sup>.

## REMOTE START

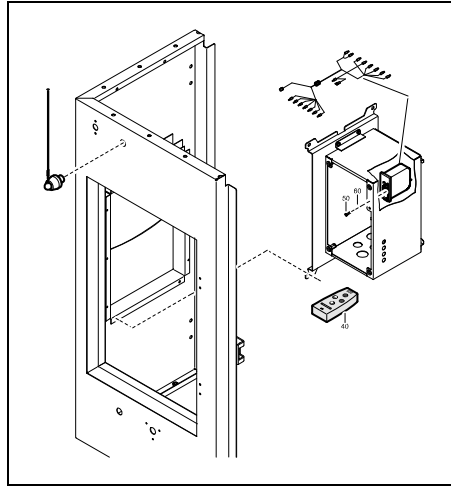

The remote start allows the user to start, stop the compressor and switch to load/noload by radiosignal.

This is particularly comfortable when the compressor can not be positioned directly at the job site because of blocking by buildings or other obstacles.

## INTERNAL LIGHTNING

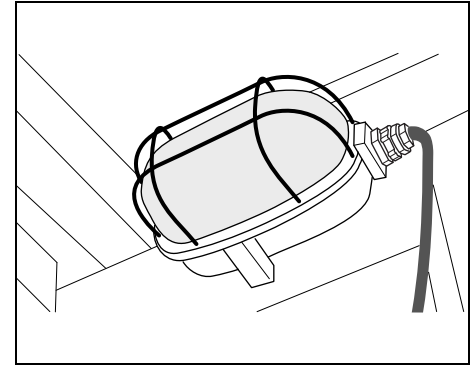

The internal lighting circuit is equipped with a timer. When the internal lighting is switched on, the timer is started. After a preset time the internal light will be switched off automatically.

# Technical specifications

## TORQUE VALUES

### GENERAL TORQUE VALUES

The following tables list the recommended torques applied for general applications at assembly of the compressor.

#### For hexagon screws and nuts with strength grade 8.8

| Thread size | Torque value (Nm / lbf.ft) |
|-------------|----------------------------|
| M6          | 9 (7)                      |
| M8          | 23 (17)                    |
| M10         | 46 (35)                    |
| M12         | 80 (60)                    |
| M14         | 125 (93)                   |
| M16         | 205 (152)                  |

#### For hexagon screws and nuts with strength grade 12.9

| Thread size | Torque value (Nm / lbf.ft) |
|-------------|----------------------------|
| M6          | 15 (12)                    |
| M8          | 39 (29)                    |
| M10         | 78 (58)                    |
| M12         | 135 (100)                  |
| M14         | 210 (155)                  |
| M16         | 345 (255)                  |

### CRITICAL TORQUE VALUES

| Assemblies                                 | Torque value (Nm / lbf.ft) |
|--|----------------------------|
| <b>Axles to frame:</b>                     |                            |
| Wheel nuts                                 | 270 (200)                  |
| Bolts, front axle/frame                    | 205 (152)                  |
| Bolts, rear axle/frame                     | 205 (152)                  |
| <b>Compressor to frame:</b>                |                            |
| Bolts, elements/gear casing                | 46 (34)                    |
| Bolts, elements/support                    | 80 (60)                    |
| Bolts, support/buffer                      | 205 (152)                  |
| Bolts, buffer/frame                        | 80 (60)                    |
| <b>Engine to frame:</b>                    |                            |
| Bolts, engine/support                      | 205 (152)                  |
| Bolts, support/buffer                      | 46 (34)                    |
| Bolts, buffer/frame                        | 23 (17)                    |
| <b>Lifting beams to frame:</b>             |                            |
| Bolts, lifting beams/yoke (M12)            | 125 (93)                   |
| Bolts, lifting beams/yoke (M16)            | 205 (152)                  |
| Bolts, lifting beams/A-Frames              | 205 (152)                  |
| Bolts, A-Frames/frame                      | 205 (152)                  |
| <b>Hose clamps:</b>                        |                            |
| Pebra hose clamps on all IC/radiator hoses | 12 (9)                     |



Secure the drain cock and tank cap of the fuel tank handtight.

## COMPRESSOR / ENGINE SPECIFICATIONS

### REFERENCE CONDITIONS

| Designation                        |        | XRXS 567 Cd - XRXS 1240 CD7<br>XRXS 607 Cd - XRXS 1275 CD7 | XRVS 617 Cd - XRVS 1300 CD7<br>XRVS 647 Cd - XRVS 1350 CD7 |
|------------------------------------|--------|--|--|
| Absolute inlet pressure            | bar(e) | 1  | 1  |
|                                    | psi    | 14.5   | 14.5   |
| Relative air humidity              | %      | 0  | 0  |
| Air inlet temperature              | °C     | 20   | 20   |
|                                    | °F     | 68   | 68   |
| Nominal effective working pressure | bar(e) | 30   | 25   |
|                                    | psi    | 435  | 363  |

The inlet conditions are specified at the air inlet grating outside the canopy.

### LIMITATIONS

| Designation  |                               | XRXS 567 Cd - XRXS 1240 CD7<br>XRXS 607 Cd - XRXS 1275 CD7 | XRVS 617 Cd - XRVS 1300 CD7<br>XRVS 647 Cd - XRVS 1350 CD7 |
|--|-------------------------------|--|--|
| Minimum effective receiver pressure                      | bar(e)                        | 19   | 16   |
|  | psi                           | 276  | 232  |
| Maximum effective receiver pressure, compressor unloaded | bar(e)                        | 32   | 27   |
|  | psi                           | 464  | 392  |
| Maximum ambient temperature at sea level                 | without aftercooler           | °C   | 50   |
|  |                               | °F   | 122  |
|  | with aftercooler              | °C   | 45   |
|  |                               | °F   | 113  |
| Minimum starting temperature                             | °C                            | -10  | -10  |
|  | °F                            | 14   | 14   |
| Minimum starting temperature, with coldstart equipment   | °C                            | -25  | -25  |
|  | °F                            | -13  | -13  |
| Altitude capability                                      | see separate curve on page 91 |  |  |



## PERFORMANCE DATA

At reference conditions, if applicable, and at normal shaft speed, unless otherwise stated.

| Designation                             |                        |       | XRXS 567 Cd -<br>XRXS 1240 CD7 | XRXS 607 Cd -<br>XRXS 1275 CD7 | XRVS 617 Cd -<br>XRVS 1300 CD7 | XRVS 647 Cd -<br>XRVS 1350 CD7 |
|---|------------------------|-------|--------------------------------|--------------------------------|--------------------------------|--------------------------------|
| Engine shaft speed, normal and maximum  |                        | r/min | 1800                           | 1900                           | 1800                           | 1800                           |
| Engine shaft speed, compressor unloaded |                        | r/min | 1300                           | 1300                           | 1300                           | 1300                           |
| Free air delivery <sup>1)</sup>         | without<br>aftercooler | l/s   | 566                            | 621                            | 606                            | 630                            |
|   |                        | cfm   | 1,199                          | 1,316                          | 1,284                          | 1,335                          |
|   | with<br>aftercooler    | l/s   | 549                            | 602                            | 588                            | 611                            |
|   |                        | cfm   | 1,163                          | 1,276                          | 1,246                          | 1,295                          |
| Fuel consumption                        |                        |       |                                |                                |                                |                                |
| - at 100% FAD                           | Fuel expert            | kg/h  | 84.3                           | 88.6                           | 82.4                           | 85.4                           |
|   |                        | lb/h  | 185.8                          | 195.3                          | 181.7                          | 188.3                          |
|   | No<br>Fuel expert      | kg/h  | 84.3                           | 88.6                           | 82.4                           | 85.4                           |
|   |                        | lb/h  | 185.8                          | 195.3                          | 181.7                          | 188.3                          |
| - at 75% FAD                            | Fuel expert            | kg/h  | 67.0                           | 67.9                           | 64.7                           | 67.0                           |
|   |                        | lb/h  | 147.7                          | 149.7                          | 142.6                          | 147.7                          |
|   | No<br>Fuel expert      | kg/h  | 73.9                           | 78.5                           | 70.0                           | 72.5                           |
|   |                        | lb/h  | 162.9                          | 173.1                          | 154.3                          | 159.8                          |
| - at 50% FAD                            | Fuel expert            | kg/h  | 54.8                           | 53.8                           | 46.3                           | 48.0                           |
|   |                        | lb/h  | 120.8                          | 118.6                          | 102.1                          | 105.8                          |
|   | No<br>Fuel expert      | kg/h  | 58.9                           | 58.3                           | 54.6                           | 56.6                           |
|   |                        | lb/h  | 129.9                          | 128.5                          | 120.4                          | 124.8                          |
| - at 25% FAD                            | Fuel expert            | kg/h  | 44.9                           | 43.2                           | 41.5                           | 43.0                           |
|   |                        | lb/h  | 99.0                           | 95.2                           | 91.5                           | 94.8                           |
|   | No<br>Fuel expert      | kg/h  | 45.1                           | 43.2                           | 41.9                           | 43.4                           |
|   |                        | lb/h  | 99.4                           | 95.2                           | 92.4                           | 95.7                           |

| Designation  |                        |                            | XRXS 567 Cd -<br>XRXS 1240 CD7 | XRXS 607 Cd -<br>XRXS 1275 CD7 | XRVS 617 Cd -<br>XRVS 1300 CD7 | XRVS 647 Cd -<br>XRVS 1350 CD7 |
|--|------------------------|----------------------------|--------------------------------|--------------------------------|--------------------------------|--------------------------------|
| - at unload  | Fuel expert            | kg/h                       | 32.9                           | 32.9                           | 30.0                           | 31.1                           |
|  |                        | lb/h                       | 72.5                           | 72.5                           | 66.1                           | 68.6                           |
|  | No<br>Fuel expert      | kg/h                       | 32.9                           | 32.9                           | 30.0                           | 31.1                           |
|  |                        | lb/h                       | 72.5                           | 72.5                           | 66.1                           | 68.6                           |
| Specific fuel consumption  | without<br>aftercooler | g/m <sup>3</sup>           | 41.4                           | 39.6                           | 37.8                           | 37.7                           |
|  |                        | lb/1000 cu.ft              | 2.58                           | 2.47                           | 2.36                           | 2.35                           |
|  | with<br>aftercooler    | g/m <sup>3</sup>           | 42.7                           | 40.9                           | 38.9                           | 38.8                           |
|  |                        | lb/1000 cu.ft              | 2.67                           | 2.55                           | 2.43                           | 2.42                           |
| Typical oil content of compressed air  |                        | mg/m <sup>3</sup> free air | 3                              | 3                              | 3                              | 3                              |
|  |                        | oz/1000 cu.ft              | 0.003                          | 0.003                          | 0.003                          | 0.003                          |
| Engine oil consumption (maximum)   |                        | g/h                        | 217.1                          | 228                            | 212                            | 220                            |
|  |                        | oz/h                       | 7.66                           | 8.04                           | 7.48                           | 7.76                           |
| Compressed air temperature at<br>outlet valve  | without<br>aftercooler | °C                         | 100                            | 100                            | 100                            | 100                            |
|  |                        | °F                         | 212                            | 212                            | 212                            | 212                            |
|  | with<br>aftercooler    | °C                         | 35                             | 35                             | 35                             | 35                             |
|  |                        | °F                         | 95                             | 95                             | 95                             | 95                             |
| Noise level  |                        |                            |                                |                                |                                |                                |
| - Sound pressure level (LP), complies with ISO 2151<br>under free field conditions at 7 m distance |                        | dB(A)                      | -                              | -                              | -                              | -                              |
| - Sound pressure level (LP), complies with EPA under<br>free field conditions at 7 m distance      |                        | dB(A)                      | 76                             | 76                             | 76                             | 76                             |
| - Sound power level (LW) complies with 2000/14/EC  |                        | dB(A)                      | 104                            | 104                            | 104                            | 104                            |

1) Free air delivery is measured according to ISO 1217 ed.3 1996 annex D

|   |  |
|---|--|
| Tolerance:  | <ul style="list-style-type: none"> <li>+/- 5% 25 l/s (53 cfm) &lt; FAD &lt; 250 l/s (530 cfm)</li> <li>+/- 4% 250 l/s (530 cfm) &lt; FAD</li> </ul>                |
| The international standard ISO 1217 corresponds to<br>following national standards: | <ul style="list-style-type: none"> <li>British BSI 1571 part 1</li> <li>German DIN 1945 Part 1</li> <li>Swedish SS-ISO 1217</li> <li>American ANSI PTC9</li> </ul> |

## ALTITUDE UNIT PERFORMANCE CURVE

Max. allowable working pressure as a function altitude and ambient temperature.

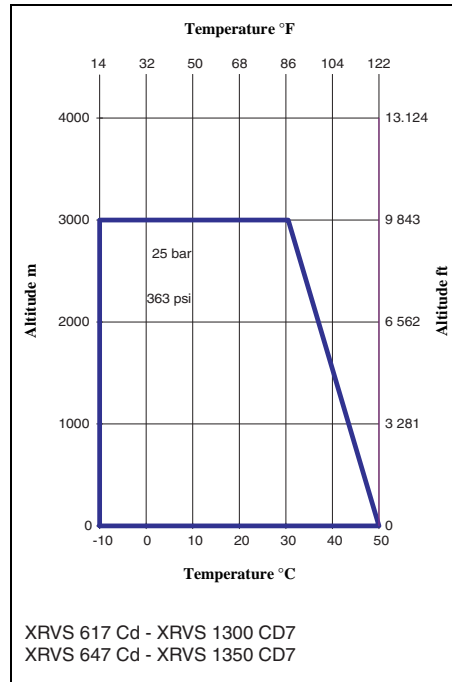
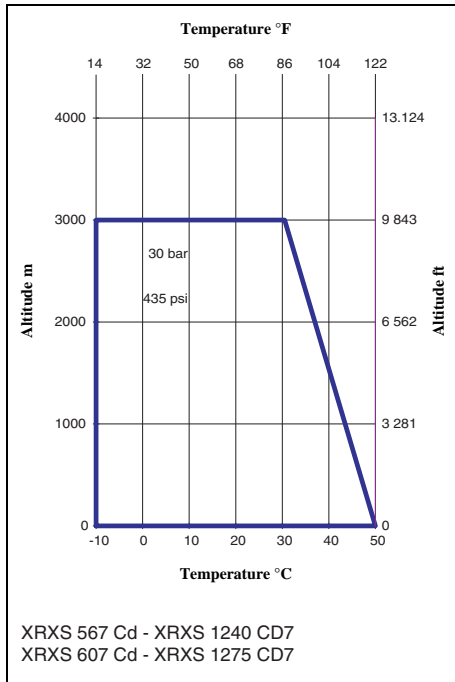

## DESIGN DATA

### Compressor

| Designation                  |   |
|------------------------------|---|
| Number of compression stages | 2 |

### Engine

| Designation                                   |       | All units   |
|---|-------|-------------|
| Make  |       | Caterpillar |
| Type  |       | C18         |
| Coolant                                       |       | Liquid      |
| Number of cylinders                           |       | 6           |
| Bore  | mm    | 145         |
|   | in    | 5.71        |
| Stroke  | mm    | 183         |
|   | in    | 7.2         |
| Swept volume                                  | l     | 18.1        |
|   | cu.in | 1104.5      |
| Output acc. to DIN 6271 at normal shaft speed | kW    | 429         |
|   | hp    | 575.3       |
| - Load factor                                 | %     | 100         |

| Designation                   |        | All units |
|-------------------------------|--------|-----------|
| Capacity of oil sump:         |        |           |
| - Initial fill                | l      | 60        |
|                               | US gal | 15.85     |
| - Refill (max.) <sup>1)</sup> | l      | 58        |
|                               | US gal | 15.32     |
| Capacity of cooling system    | l      | 52        |
|                               | US gal | 13.74     |

<sup>1)</sup> With filter change.

## Unit

| Designation  |                   | All units |
|--|-------------------|-----------|
| Capacity of compressor oil system  | l                 | 82        |
|  | US gal            | 21.66     |
| Net capacity of air receiver   | l                 | 143       |
|  | US gal            | 37.78     |
| Capacity of fuel tank (standard)   | l                 | 975       |
|  | US gal            | 257.6     |
| Capacity of fuel tanks<br>- with skid or support mounted<br>- with option large fuel tanks | l                 | 1550      |
|  | US gal            | 409.5     |
| Air volume at inlet grating<br>(approx.) <sup>1)</sup>                                     | m <sup>3</sup> /s | 13.9      |
|  | cu.ft/s           | 491       |

<sup>1)</sup> Air required for engine and compressor element cooling, for combustion and for compression.

## Electric refuel pump

| Designation                    |          | All units |
|--------------------------------|----------|-----------|
| Flow rate *)                   | l/m      | 50        |
|                                | US gal/m | 13        |
| Self priming *) from dry up to | m        | 2.4       |
|                                | ft       | 7.8       |

\*) Fuel temperature max 40 °C (104 °F)

## Remote control

| Designation |    | All units |
|-------------|----|-----------|
| Range *)    | m  | 200       |
|             | ft | 656       |

\*) Obstacles and position of user in relation to receiver (at the rear of the unit) will reduce the range.

## Compressor dimensions

| Designation                    |      | All units               |
|--------------------------------|------|-------------------------|
| Dimensions (overall) L x W x H |      |                         |
| Wagon towbar raised            | m    | 5.40 x 2.25 x 2.51      |
|                                | inch | 233.86 x 88.58 x 101.46 |
| Tandem EU                      | m    | 6.80 x 2.53 x 3.04      |
|                                | inch | 267.71 x 99.61 x 119.69 |
| Support mounted                | m    | 4.56 x 2.25 x 2.27      |
|                                | inch | 179.53 x 88.58 x 89.37  |
| Skid                           | m    | 4.56 x 2.25 x 2.44      |
|                                | inch | 179.53 x 88.58 x 96.06  |

| Designation                              |    | All units     |
|--|----|---------------|
| Weight (dry)                             |    |               |
| Wagon                                    | kg | 7200          |
|  | lb | 15875         |
| Tandem EU                                | kg | 8605          |
|  | lb | 18971         |
| Support mounted (option large fuel tank) | kg | 6555 (6685)   |
|  | lb | 14450 (14740) |
| Skid (option large fuel tank)            | kg | 6775 (6095)   |
|  | lb | 14940 (15225) |
| Weight (wet, incl. fuel)                 |    |               |
| Wagon                                    | kg | 8200          |
|  | lb | 18080         |
| Tandem EU                                | kg | 10100         |
|  | lb | 22267         |
| Support mounted (option large fuel tank) | kg | 7555 (8180)   |
|  | lb | 16655 (18035) |
| Skid (option large fuel tank)            | kg | 7775 (8400)   |
|  | lb | 17140 (18520) |

# Dataplate

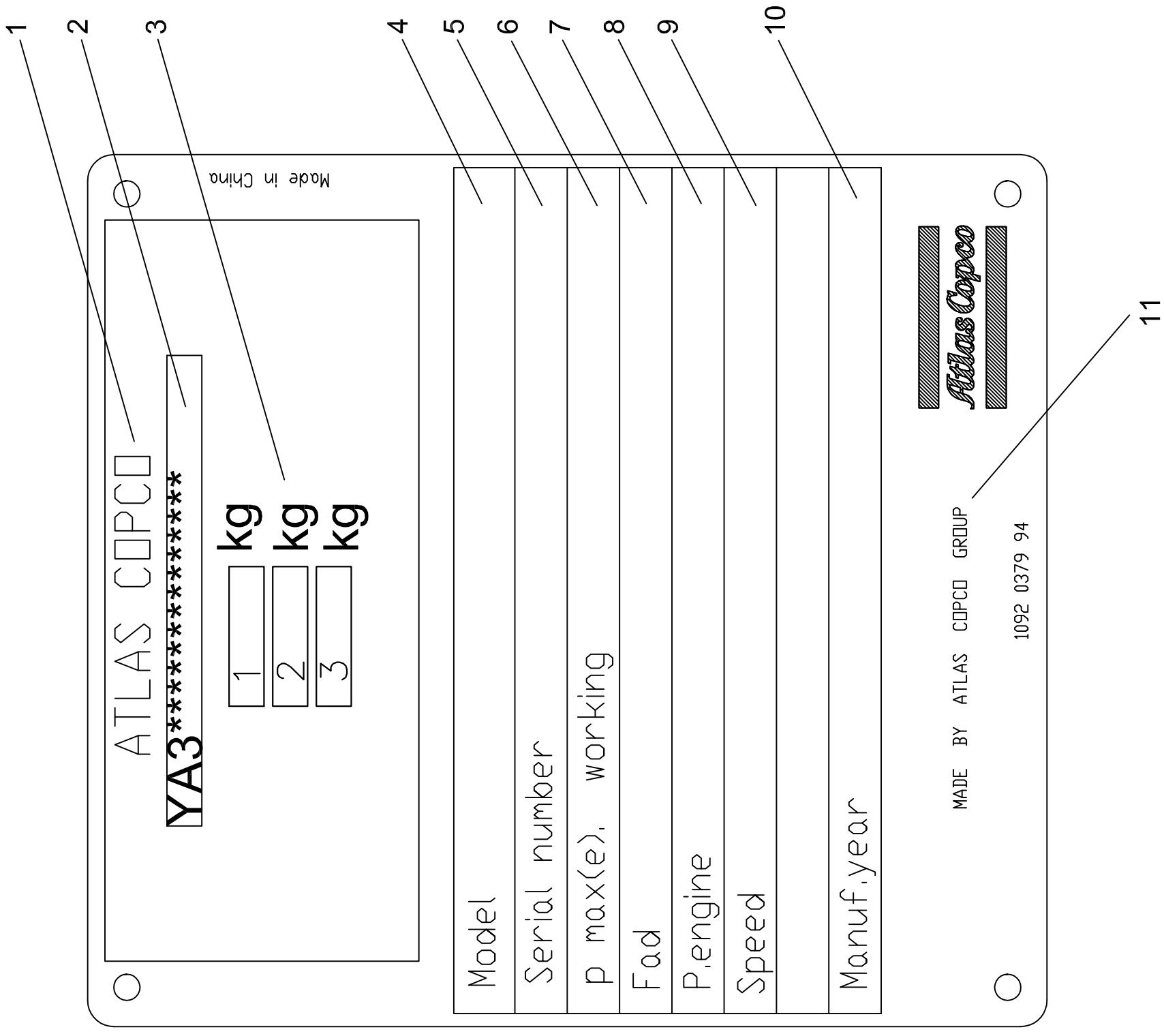

- 1 Company
- 2 Vehicle Identification number
- 3 Weight
- 4 Compressor Model
- 5 Compressor Serial number
- 6 Working Pressure
- 7 Free air delivery
- 8 Engine speed
- 9 Engine Power
- 10 Manufacture date
- 11 Manufacturer

# Legislation

## PARTS, SUBJECTED TO PRESSURE EQUIPMENT DIRECTIVE 97/23/EC, CAT. II AND ABOVE

Safety valve: cat. IV

| Designation        |        | XXRS 567 Cd - XXRS 1240 CD7<br>XXRS 607 Cd - XXRS 1275 CD7 | XRVS 617 Cd - XRVS 1300 CD7<br>XRVS 647 Cd - XRVS 1350 CD7 |
|--------------------|--------|--|--|
| Set pressure       | bar(e) | 35   | 30   |
|                    | psi    | 508  | 435  |
| Design temperature | °C     | 130  | 130  |
|                    | °F     | 266  | 266  |

Air Oil separator

| Designation             |         | Standard | Cold start equipment |
|-------------------------|---------|----------|----------------------|
| Design pressure         | bar(e)  | 35       | 35                   |
|                         | psi     | 508      | 508                  |
| Design temperature max. | °C      | 130      | 130                  |
|                         | °F      | 266      | 266                  |
| Design temperature min. | °C      | -25      | -25                  |
|                         | °F      | -13      | -13                  |
| Volume                  | l       | 143      | 143                  |
|                         | US gal  | 37.7     | 37.7                 |
|                         | Imp gal | 31.5     | 31.5                 |
|                         | cu.ft   | 5        | 5                    |



**PARTS, SUBJECTED TO CAT. I AND COVERED BY THE MACHINE DIRECTIVE 89/392/EC**

**All other parts**

**PARTS, SUBJECTED TO ART. I, PARAGRAPH 3.3**

**All other parts**

# Disposal

## GENERAL

When developing products and services, Atlas Copco tries to understand, address, and minimize the negative environmental effects that the products and services may have, when being manufactured, distributed, and used, as well as at their disposal.

Recycling and disposal policy are part of the development of all Atlas Copco products. Atlas Copco company standards determine strict requirements.

Selecting materials the substantial recyclability, the disassembly possibilities and the separability of materials and assemblies are considered as well as the environmental perils and dangers to health during the recycling and disposal of the unavoidable rates of not recyclable materials.

Your Atlas Copco compressor consists for the most part of metallic materials, that can be remelted in steelworks and smelting works and that is therefore almost infinite recyclable. The plastic used is labelled; sorting and fractioning of the materials for recycling in the future is foreseen.



**This concept can only succeed with your help. Support us by disposing professionally. By assuring a correct disposal of the product you help to prevent possible negative consequences for environment and health, that can occur with an inappropriate waste handling.**

**Recycling and re-usage of material helps to preserve natural resources.**

## DISPOSAL OF MATERIALS

Dispose contaminated substances and material separately, according to local applicable environmental legislations.

Before dismantling a machine at the end of its operating lifetime drain all fluids and dispose of according the applicable local disposal regulations.

Remove the batteries. Do not throw batteries into the fire (explosion risk) or into the residual waste. Separate the machine into metal, electronics, wiring, hoses, insulation and plastic parts.

Dispose all components according to the applicable disposal regulations.

Remove spilled fluid mechanically; pick up the rest with absorbing agent (for example sand, sawdust) and dispose it according the applicable local disposal regulations. Do not drain into the sewage system or surface water.







