



GETZ MANUFACTURING
PART NO.: 58630
MODEL: MS 36 SC
HYDROSTATIC TEST PUMP

GETZ AIR POWERED HYDROSTATIC TEST PUMP

MODEL #MS 36 SC

TABLE OF CONTENTS

PAGE #

1-2	SET-UP AND OPERATING PROCEDURES
3-4	PARTS LIST
5-6	SCHEMATICS

OPERATING INSTRUCTIONS FOR FIRE EXTINGUISHER TESTING

1. Equipment needed prior to hydro testing fire extinguishers that are not provided with the Getz model #MS36SC hydrostatic test pump:
 - A. Safety glasses
 - B. Hydrostatic test adapters
 - C. Regulator
 - D. Garden Hose
2. WARNING:
 - A. Do not exceed 90 PSI of incoming air supply.
 - B. Do not operate without approved safety glasses.
 - C. Do not modify any components within this system. Any use of parts other than Getz Manufacturing components excludes all written and implied liabilities.
 - D. Maximum testing pressure for this pump, model #MS36SC, is 850 PSI.

SETUP AND OPERATING PROCEDURES

1. Connect swivel fitting (#4) to the male end of your garden hose and tighten securely. Then, connect female fitting on garden hose to clean water supply.
2. Close ball valve (#8) and open water supply valve and check for leaks.
3. Remove plastic connector (#44) from yellow tubing (#18) and thread tape or place sealant on male pipe threads. Screw connector (#44) into the outlet port of your regulator and reconnect yellow tubing (#18) to the plastic connector (#44) in your regulator. Make sure ball valve (#12) is closed and set regulator to 90 PSI.
4. Place drain hose (#39) in an approved waste water drain and secure drain hose to floor or wall.
5. Place correct test adapter in extinguisher being tested and slip the head gasket (#64) over the small threads on the test adapter. Place head assembly (#41) on top of the head gasket (#64) and tighten the head assembly on the extinguisher adapter by spinning the spin clamp (#42) down firmly on the head assembly (#41)
6. Check manufacturer's recommended test pressure on extinguisher to verify test pressure. Place extinguisher in test cage (#35) and close and latch.
7. Connect quick coupler (#32) into the test adapter in the extinguisher. Make sure quick is firmly attached to test adapter.
8. Place safety cage (#35) in upright position and open ball valve (#43), then open ball valve (#8). As a steady stream of water appears in drain line (#39), close ball valve (#43).
9. Invert safety cage (#35) upside down so extinguisher is tested in upside down position.
10. Push on air valve (#16) until manufacturer's recommended test pressure is shown on test pressure gauge (#19) for the extinguisher being tested.

SETUP AND OPERATING PROCEDURES (CONT.)

11. Maintain pressure in extinguisher until MFPA 10/state test time is met.
12. Close ball valve (#8), open ball valve (#43), and then open ball valve (#12) to allow water to be forced out of the extinguisher by air pressure.
13. When no water is apparent in drain line (#39), close ball valve (#12).
14. After verifying that no pressure is shown on test pressure gauge (#19), investment cage (#35) to upright position and remove quick coupler (#32) for test adapter.
15. Remove extinguisher for test gauge (#35) and remove head assembly and test adapter. Place extinguisher on drying rack.
16. After all extinguishers have been tested, shut off water and air supply lines to system.

PARTS LIST

<u>NO.</u>	<u>PART #</u>	<u>DESCRIPTION</u>
1	59172	STRAINER Y 1/4 SPORLAN W/ORING
2	51650	PIPE NIP BR 1/4 X 1 1/2
3	51684	PIPE RDCR BR 1/2 X 1/4
4	51335	FTNG SWIVEL WATER
5	51948	WASHER FILTER N 107
6	51653	PIPE NIP BR 1/4 X 3 1/2
7	51624	PIPE ELB 1/4 ST
8	51903	VLV BALL BR 1/4 WATER TESTER
9	51912	VLV CHECK 1/4 M6
10	51683	PIPE RDCR BR 3/8 X 1/4
11	51697	PIPE TEE BR 1/4 ST
12	51899	VLV BALL 1/4 X 1/4 ML
13	51696	PIPE TEE BR 1/4 FMLE
14	53564	PIPE ELB 1/8 NPT X 5/32 TUBE
15	51556	MTL NYLON TUBE 5/32
16	51943	VLV SMC PUSH BUTTON
17	51638	PIPE ELB PLAS 1/4 ML X 1/4 TUBE
18	51553	MTL NYCOIL 1/4 YL
19	51361	GUAGE 1500 PSI GLY (SPAN)
20	51628	PIPE ELB 45 DEG ST
21	51937	VLV PRESS RLF 850 PSI
22	51695	PIPE TEE BR 1/4 BOX
23	51650	PIPE NIP BR 1/4 X 1 1/2
24	51031	SWIVEL FEMALE 1/4
25	51719	PLATE BASE WATER TESTER
26	51681	PIPE RDCR 1/4 X 1/8
27	51646	PIPE NIP BR 1/8 X 1 1/2
28	52820	VLV NEEDLE DOT PUMP
29	51639	PIPE ELB SMC 1/4
30	51738	PUMP AIR HASKEL MS36
31	58583	PIPE ELB ST W/ 3/16 TUBE
32	51035	AD Q/CONNECT HANSEN 1/4
33	56014	HOSE SYNFLEX 41 MALE FL
34	56013	HOSE SYNFLEX 41 MALE EL
35	51171	CAGE SAFETY
36	51838	STAND WATER TESTER
37	51109	BARB HOSE BR 1/2 X 1/4
38	51207	CLAMP OETIKER 3/4
39	51570	MTL VINYL TUBE 1/2 CLR

PARTS LIST (CONT.)

<u>NO.</u>	<u>PART #</u>	<u>DESCRIPTION</u>
40	59177	AD # 7 AMER STOP FIRE MAP
41	51389	HEAD ASY
42	51209	CLAMP SPIN
43	51904	VLV BALL SS 1/4 WATER TESTER
44	51237	CONN PLAS 1/4 ML X 1/4 TUBE
45	51131	BKT WATER FILTER MS21SC
46	51317	FLTR WATER TESTER
47	51682	PIPE RDCR BR 3/4 X 1/4
48	51650	PIPE NIP BR 1/4 X 1 1/2
49	52083	PIPE ELB 1/8 STR BR
50	51309	REPLACEMENT FILTER
51	58688	LEXAN PANEL FOR W TESTER
52	52210	TIMER DIGITAL FOR HYDROS
53	51345	GASKET HEAD
54	51624	PIPE ELB BR 1/4 ST
55	54025	WRENCH WATER FILTER
56	53061	VLV PRESS RLF 40 PSI

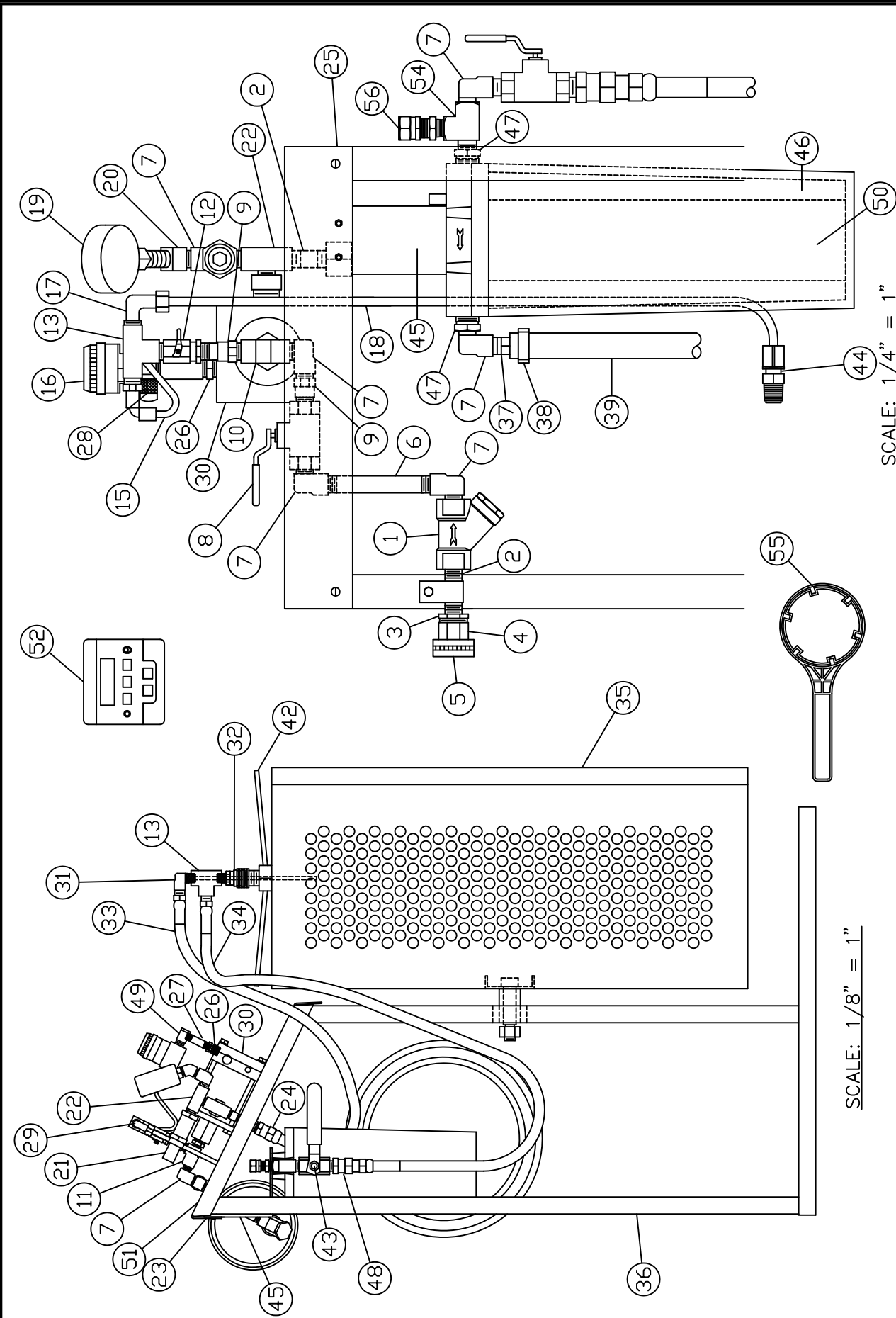

SCALE: 1/4" = 1"

SCALE: 1/8" = 1"

THIS DRAWING IS THE EXCLUSIVE AND CONFIDENTIAL PROPERTY OF GETZ MFG. IT SHALL NOT BE DUPLICATED, USED OR DISCLOSED TO OTHERS WITHOUT THE EXPRESS WRITTEN CONSENT OF GETZ MANUFACTURING.

F		CHANGED ITEM NUMBERS TO REFLECT CHANGES IN BILL OF MATERIAL		M	S	3/14	11	DATE	
REV		DRAWING CHANGE		BY	ECN NO.	DATE		FINISH	
				J.A.L.		K.L.R.		K.L.R.	
		TOLERANCES UNLESS OTHERWISE SPECIFIED		SCALE		DATE		TITLE	
FRAC. ±.020		2 PL DEC ±.010 3 PL DEC ±.003		1/8" = 1"		3-11-92		TESTER WATER COMP	
								AMEREX GETZ	
								GETZ MANUFACTURING NORTH PEKIN, IL	
								SHEET NO. 1 OF 2	
								BIN NO.	
								DWG. NO. 58630-M	
								REV. F	

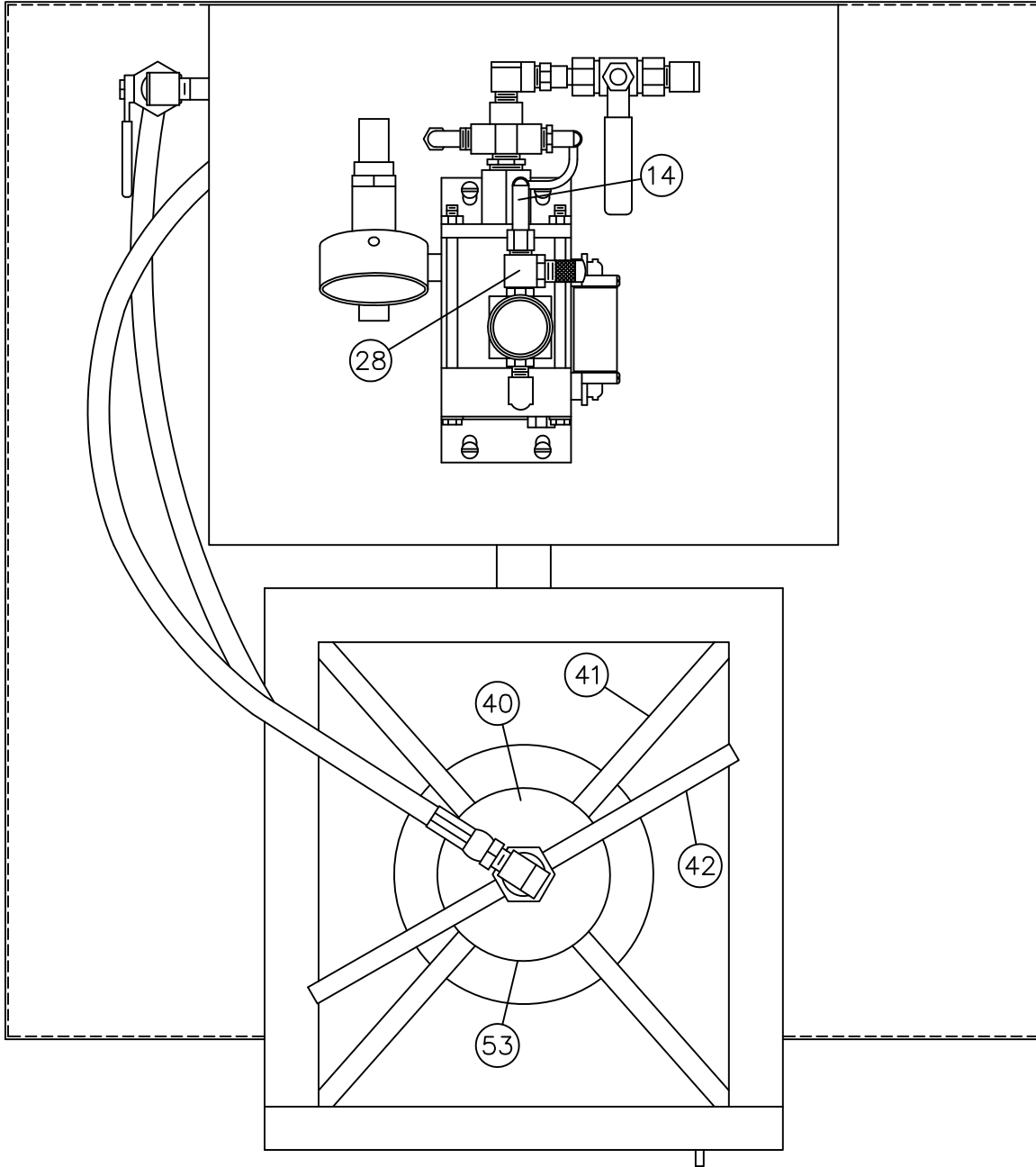

B	CHANGED ITEM NUMBER TO REFLECT CHANGES IN BILL OF MATERIAL	M	S	3/14	11	THIS DRAWING IS THE EXCLUSIVE AND CONFIDENTIAL PROPERTY OF GETZ MFG. IT SHALL NOT BE DUPLICATED, USED OR DISCLOSED TO OTHERS WITHOUT THE EXPRESS WRITTEN CONSENT OF GETZ MANUFACTURING.	
A	CHANGED ITEM NUMBER FROM 64 TO 57	R	M	5/1	02	MATERIAL	FINISH
REV	DRAWING CHANGE	BY	ECN NO.	DATE		DWN BY	CK'D
	TOLERANCES UNLESS OTHERWISE SPECIFIED					J.A.L.	K.L.R.
	FRAC. ±.020	2 PL DEC ±.010	3 PL DEC ± .003				DATE
							3-11-92
							TITLE
							TESTER WATER COMP
							DWG. NO.
							58630-2M
							REV.
							B
							SHEET NO.
							2 OF 2
							BIN NO.

